

# INSTALLATION INSTRUCTIONS

(-)ACL HIGH EFFICIENCY R-410A COMMERCIAL CONDENSING UNITS  
NOMINAL SIZES 10, 12.5, 15 & 20 TONS

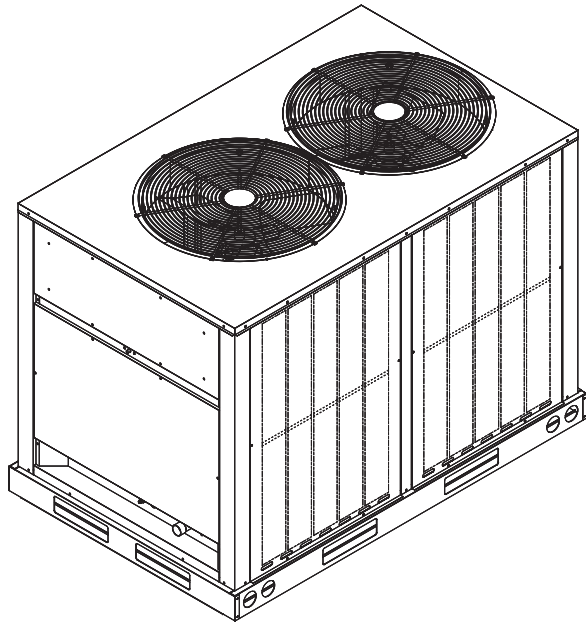

10 & 12.5 TON

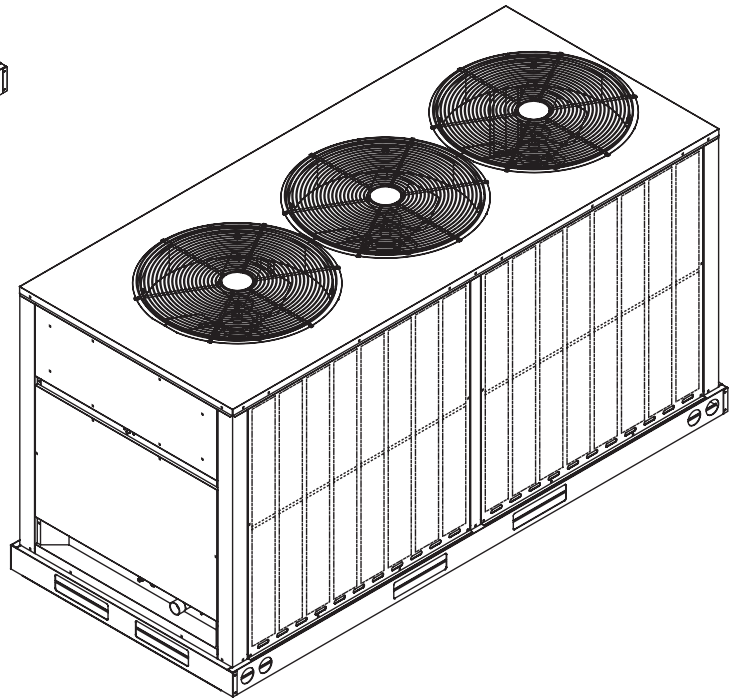

15 & 20 TON



Recognize this symbol as an indication of Important Safety Information!

**DO NOT DESTROY. PLEASE READ CAREFULLY AND  
KEEP IN A SAFE PLACE FOR FUTURE REFERENCE.**



## WARNING

THESE INSTRUCTIONS ARE INTENDED AS AN AID TO QUALIFIED, LICENSED SERVICE PERSONNEL FOR PROPER INSTALLATION, ADJUSTMENT AND OPERATION OF THIS UNIT. READ THESE INSTRUCTIONS THOROUGHLY BEFORE ATTEMPTING INSTALLATION OR OPERATION. FAILURE TO FOLLOW THESE INSTRUCTIONS MAY RESULT IN IMPROPER INSTALLATION, ADJUSTMENT, SERVICE OR MAINTENANCE POSSIBLY RESULTING IN FIRE, ELECTRICAL SHOCK, PERSONAL INJURY OR PROPERTY DAMAGE.

# TABLE OF CONTENTS

<b>1.0 Important Safety Information</b>	<b>3</b>
<b>2.0 General Information</b>	<b>4</b>
2.1 Introduction	4
2.2 Importance of a Quality Installation	4
2.3 System Sizing and Selection	4
2.4 Importance of Proper Indoor/Outdoor Match-Ups	5
2.5 Checking Product Received	5
2.6 Efficiency Testing Notice	5
2.7 Compressor Break-In Note	5
<b>3.0 Unit Specifications</b>	<b>6</b>
3.1 Model Number Nomenclature	6
3.2 Physical and Electrical Data	7
3.3 Unit Features	10
<b>4.0 Installation</b>	<b>12</b>
4.1 Tools & Refrigerant	12
4.1.1 Tools Required for Installing & Servicing R-410A Models	12
4.1.2 Specifications of R-410A	12
4.1.3 Quick Reference Guide for R-410A	12
4.2 Choosing a Location	13
4.2.1 Allowable Clearances	13
4.2.2 Operational Issues Related to Unit Location	13
4.2.3 Corrosive Environments	14
4.2.4 Customer Satisfaction Issues	14
4.3 Rigging and Mounting Unit	14
4.3.1 Corner Weights Rigging	14
4.3.2 Unit-Mounting Methods	15
4.3.3 High Wind and Seismic Tie-Down Methods	15
4.4 Refrigerant Line Set Selection	16
4.4.1 Replacing Existing Systems	16
4.4.2 Line Set Length and Fitting Losses	16
4.4.3 Liquid Line Selection	16
4.4.4 Suction Line Selection	18
4.4.5 Long Line Length Considerations	18
4.4.5.1 Oil Return to Compressor	18
4.4.5.2 Refrigerant Migration During Off-Cycle	18
4.4.5.3 Maximum Liquid Pressure Drop	18
4.4.5.4 Liquid Line Refrigerant Flashing	18
4.4.5.5 Compressor Oil Level Adjustment	19
4.4.5.6 Capacity Losses	19
4.5 Line Set Installation	20
4.5.1 Important Tubing Installation Practices	20
4.5.2 Relative Location of Indoor and Outdoor Units	21
4.5.2.1 Indoor and Outdoor Unit Near Same Level	21
4.5.2.2 Outdoor Unit Below Indoor Unit	22
4.5.2.3 Outdoor Unit Above Indoor Unit	23
4.5.3 Tubing Connections	24
4.6 Initial Leak Testing	25
4.7 Evacuation	25
4.8 Control Wiring	26
4.9 Typical Field Wiring Connections	26
4.10 Configuring Control Transformer for 208V Applications	27
4.11 Power Wiring	27
4.12 Grounding	27

<b>5.0 Refrigerant Charging and System Start-Up</b>	<b>28</b>
5.1 Start-Up Overview	28
5.2 Preliminary Charging by Weight and Final Leak Check	28
5.3 Pre-Start Check	29
5.4 Initial System Power-Up – Verifying Correct Indoor Blower Motor and Compressor Rotation	30
5.5 Verifying Indoor Air-Flow	30
5.6 Charging	30
5.7 Charging Charts	32
5.8 Completing Installation	36
<b>6.0 Sequence of Operation</b>	<b>36</b>
6.1 (-)ACL2120 Two-Stage Compressor	36
6.2 (-)ACL2150, (-)ACL2180, (-)ACL2240 Tandem Compressor	36
<b>7.0 Components &amp; Controls</b>	<b>37</b>
7.1 Compressor	37
7.2 Outdoor Fan Motor	37
7.3 Outdoor Fan	37
7.4 Compressor Contactor	37
7.5 Compressor Crankcase Heater	37
7.6 High and Low Pressure Controls	37
7.7 Transformer	37
7.8 Line Voltage Terminal Block for Field Connections	38
7.9 Transformer	38
<b>8.0 Accessories</b>	<b>38</b>
8.1 Liquid Line Solenoid	38
8.2 Sight Glass	38
8.3 Low Ambient Control (LAC) (RXAD-08)	38
<b>9.0 Diagnostics and Troubleshooting</b>	<b>39</b>
9.1 Cooling Mechanical Checks Flowchart	39
9.2 General Troubleshooting Guide	40
9.3 Service Analyzer Charts	41
9.4 Troubleshooting Tips	46
<b>10.0 Outdoor Unit Maintenance</b>	<b>47</b>
10.1 Outdoor Coil Cleaning	47
10.2 Cabinet Cleaning and Care	47
10.3 Motor Lubrication	47
10.4 Replacement Parts	47
<b>11.0 Wiring Diagrams</b>	<b>48</b>

# 1.0 IMPORTANT SAFETY INFORMATION

## **⚠️ WARNINGS:**

- These instructions are intended as an aid to qualified, licensed service personnel for proper installation, adjustment, and operation of this unit. Read these instructions thoroughly before attempting installation or operation. Failure to follow these instructions may result in improper installation, adjustment, service, or maintenance possibly resulting in fire, electrical shock, property damage, personal injury, or death.
- The unit must be permanently grounded. Failure to do so can cause electrical shock resulting in severe personal injury or death.
- Turn off electric power at the fuse box or service panel before making any electrical connections.
- Complete the ground connection before making line voltage connections. Failure to do so can result in electrical shock, severe personal injury, or death.
- Disconnect all power to unit before starting maintenance. Failure to do so can cause electrical shock resulting in severe personal injury or death.
- Never assume the unit is properly wired and/or grounded. Always test the unit cabinet with a noncontact voltage detector available at most electrical supply houses or home centers before removing access panels or coming into contact with the unit cabinet.
- Do not use oxygen to purge lines or pressurize system for leak test. Oxygen reacts violently with oil, which can cause an explosion resulting in severe personal injury or death.
- The top of the scroll compressor shell is hot. Touching the compressor top may result in serious personal injury.
- The manufacturer's warranty does not cover any damage or defect to the unit caused by the attachment or use of any components, accessories, or devices (other than those authorized by the manufacturer) into, onto, or in conjunction with the heat pump. You should be aware that the use of unauthorized components, accessories, or devices may adversely affect the operation of the heat pump and may also endanger life and property. The manufacturer disclaims any responsibility for such loss or injury resulting from the use of such unauthorized components, accessories, or devices.

## **⚠️ CAUTIONS:**

- R-410A systems operate at approximately 60% higher pressures (1.6 times) than R-22 systems. Do not use R-22 service equipment or components on R-410A equipment. Use appropriate care when using this refrigerant. Failure to exercise care may result in equipment damage or personal injury.
- Only match this outdoor unit with a matched indoor coil or air handler approved for use with this outdoor unit per the unit manufacturer's specification sheet. The use of unmatched coils or air handler will likely result in a charge imbalance between the cooling and heating modes which can cause unsatisfactory operation including a high-pressure switch lockout condition.
- Only use indoor coils approved for use on R-410A systems. An R-22 coil will have a TXV or fixed restrictor device that is not designed to operate properly in an R-410A system and will result in serious operational issues. The R-22 coil could also contain mineral oil which is incompatible with the POE oil used in R-410A systems and could result in reliability issues with the compressor and TXVs.
- When coil is installed over a finished ceiling and/or living area, it is required that a secondary sheet metal condensate pan be constructed and installed under the entire unit. Failure to do so can result in property damage.
- The compressor has an internal overload protector. Under some conditions, it can take up to 2 hours for this overload to reset. Make sure overload has had time to reset before condemning the compressor.

# 2.0 GENERAL INFORMATION

## **⚠WARNING:**

Improper installation, or installation not made in accordance with these instructions, can result in unsatisfactory operation and/or dangerous conditions and can cause the related warranty not to apply.

## 2.1 Introduction

The information contained in this manual has been prepared to assist in the proper installation, operation, and maintenance of the air conditioning system.

Read this manual and any instructions packaged with separate equipment required to make up the system prior to installation. Homeowner should retain this manual for future reference.

## 2.2 Importance of Quality Installation

A quality installation is critical to assure safety, reliability, comfort, and customer satisfaction. Strict adherence to applicable codes, the information in this installation manual, the outdoor unit installation manual, and the thermostat installation manual are key to a quality installation. Read the entire instruction manuals before starting the installation.

**IMPORTANT:** This product has been designed and manufactured to meet certified AHRI capacity and efficiency ratings with the appropriate outdoor units. However, proper refrigerant charge, proper airflow, and refrigerant line sizing are critical to achieve optimum capacity and efficiency and to assure reliable operation. Installation of this product should follow the manufacturer's refrigerant charging and airflow instructions located in this installation manual and the charging chart label affixed to the outdoor unit. Failure to confirm proper charge and airflow may reduce energy efficiency and shorten equipment life.

The equipment has been evaluated in accordance with the Code of Federal Regulations, Chapter XX, Part 3280.

Install the unit in accordance with applicable national, state, and local codes. Latest editions are available from: "National Fire Protection Association, Inc., Batterymarch Park, Quincy, MA 02269." These publications are:

- ANSI/NFPA No. 70-(Latest Edition) National Electrical Code.

- NFPA90A Installation of Air Conditioning and Ventilating Systems.

- NFPA90B Installation of warm air heating and air conditioning systems.

Install the indoor unit in such a way as to allow necessary access to the coil/filter rack and blower/control compartment.

## 2.3 System Sizing and Selection

Before specifying any air-conditioning equipment, a survey of the structure and heat gain calculation must be made. A heat gain calculation involves identifying all surfaces and openings that gain heat from the surrounding air and quantifying that heat to determine the amount of heat that needs to be removed. A heat gain calculation also calculates the extra heat load caused by sunlight and for humidity removal. These factors must be considered before selecting an air-conditioning system to provide year-round comfort. The Air Conditioning Contractors of America (ACCA) Manual N method of load calculation is one recognized procedure for determining the cooling load for commercial buildings.

After the proper equipment combination has been selected, satisfying both sensible and latent requirements, the system must be properly installed. Only then can the system provide the comfort it was designed to provide.

There are several factors that installers must consider.

- Outdoor unit location
- Indoor unit blower speed and airflow
- Proper equipment evacuation
- Supply and return air duct design and sizing
- Refrigerant charge
- System air balancing
- Diffuser and return air grille location and sizing

**IMPORTANT:** Excessive use of elbows in the refrigerant line set can produce excessive pressure drop. Follow industry best practices for installation. Installation and commissioning of this equipment is to be performed by trained and qualified HVAC professionals. For technical assistance, contact your Distributor Service Coordinator.

# 2.0 GENERAL INFORMATION

## 2.4 Importance of Proper Indoor/Outdoor Match-Ups

To assure many years of reliable operation and optimum customer comfort and to assure the outdoor unit warranty remains valid, an air-handler model or indoor coil should be selected that is properly matched to the outdoor unit. The recommended approach is to select an air-handler or indoor coil that has an AHRI match with the outdoor unit. Refer to the AHRI directory at [www.ahridirectory.org](http://www.ahridirectory.org) to confirm the air-handler and outdoor unit are a certified combination in the AHRI Directory.

## 2.5 Checking Product Received

Upon receiving unit, inspect it for any shipping damage. Claims for damage, either apparent or concealed, should be filed immediately with the shipping company. Check model number, electrical characteristics, and accessories to determine if they are correct. Check system components (outdoor unit, air handler, etc.) to make sure they are properly matched.

## 2.6 Efficiency Testing Notice

For purposes of verifying or testing efficiency ratings, the test procedure in Title 10, Chapter II, Subchapter D, Part 431, Subpart F, Section 96 and the clarifying provisions provided in the AHRI Operations Manual 340/360 that were applicable at the date of manufacture should be used for test set up and performance.

## 2.7 Compressor Break-In Notice

Prior to agency testing, unit must be charged at 95°F [35°C] dry bulb outdoor 80°F [26.7°C] dry bulb/67°F [19.4°C] wet bulb Indoor then unit must be run for 20 hours at 115°F [46.1°C] outdoor ambient temperature with 80°F [26.7°C] dry bulb/75°F [23.9°C] wet bulb indoor ambient temperature to break the compressor in. After the 20 hours break-in bring the rooms down to 95°F [35°C] dry bulb outdoor 80°F [26.7°C] dry bulb/67°F [19.4°C] wet bulb Indoor and perform the final charge based on sub-cooling listed on the charging chart.

# 3.0 UNIT SPECIFICATIONS

## 3.1 Model Number Nomenclature

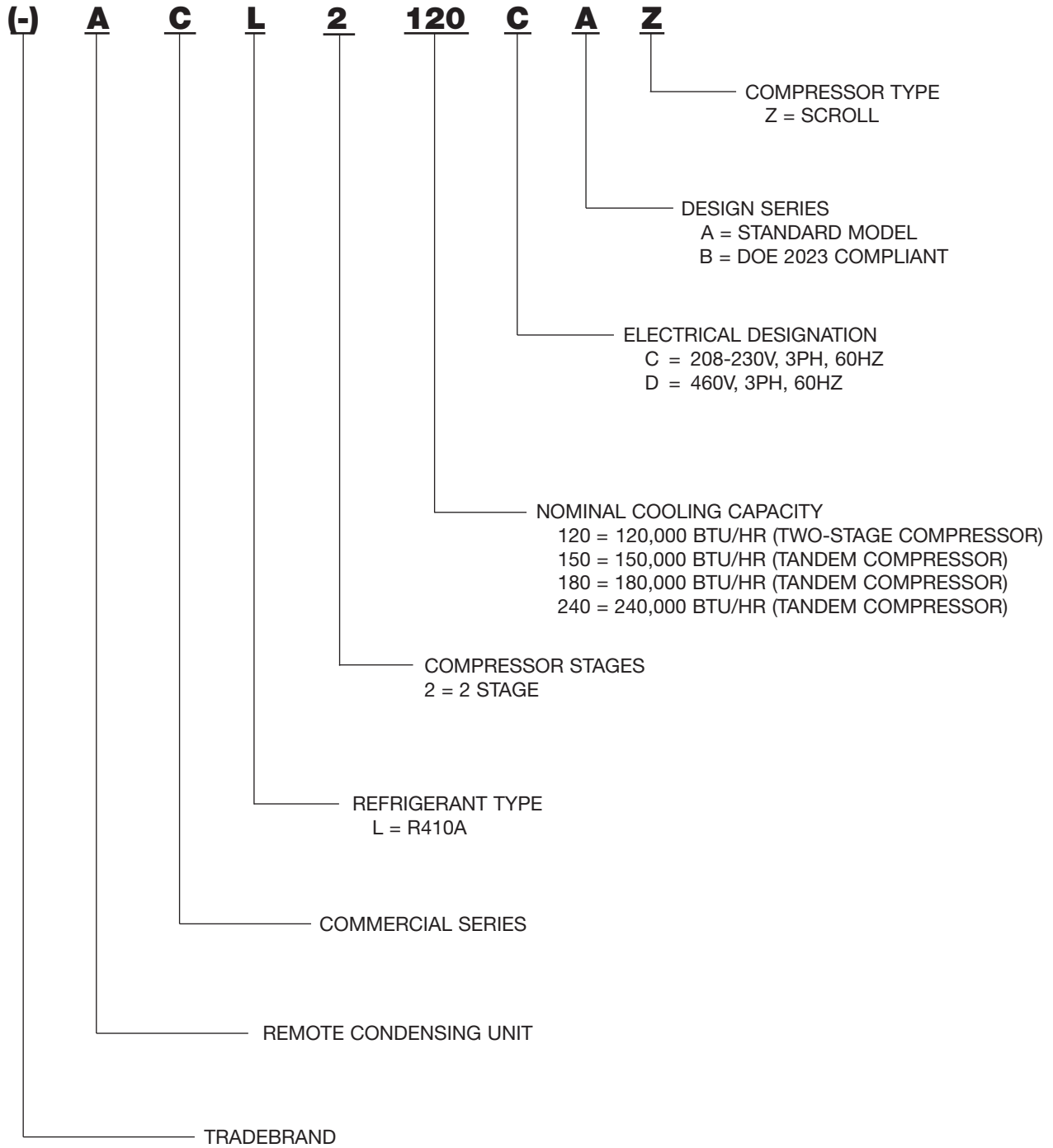

# 3.0 UNIT SPECIFICATIONS



## 3.2 Electrical and Physical Data

### 3.2 PHYSICAL DATA AND ELECTRICAL DATA

Model Number (-)ACL2	Electrical								Physical						
	Phase Frequency (Hz) Voltage (Volts)	Number of Compressors	Compressor		Number of Fans	Fan Motor Full Load Amperes (FLA) Combined	Minimum Circuit Ampacity Amperes	Fuse or HVAC Circuit Breaker		Outdoor Coil			Refrigerant Charge Oz. [g]	Weight	
			Rated Load Amperes (RLA) Combined	Locked Rotor Amperes (LRA) Combined				Minimum Amperes	Maximum Amperes	Face Area Sq. Ft. (m <sup>2</sup> )	No. Rows	CFM [L/s]		Net Lbs. [kg]	Shipping Lbs. [kg]
REV. 11/18/2019															
120C	3-60-208/230	1	32.6	240	2	7.8	49	60	80	32.88 (3.05)	2	8000 (16,951)	422 (11,964)	565 (1,246)	605 (1,334)
120D	3-60-460	1	14.8	130	2	5.0	24	30	35	32.88 (3.05)	2	8000 (16,951)	422 (11,964)	565 (1,246)	605 (1,334)
150C	3-60-208/230	2*	34.5	274	2	9.4	53	70	80	32.88 (3.05)	2	11400 (24,155)	414 (11,737)	647 (1,427)	751 (1,656)
150D	3-60-460	2*	19.4	152	2	5.0	30	35	45	32.88 (3.05)	2	11400 (24,155)	414 (11,737)	647 (1,427)	751 (1,656)
180C	3-60-208/230	2*	41.0	376	3	15.9	68	80	100	40.38 (3.75)	3	12000 (25,427)	582 (16,500)	832 (1,835)	968 (2,134)
180D	3-60-460	2*	23.2	196	3	7.5	37	45	50	40.38 (3.75)	3	12000 (25,427)	582 (16,500)	832 (1,835)	968 (2,134)
240C	3-60-208/230	2*	67.9	480	3	15.9	101	120	160	40.38 (3.75)	3	12000 (25,427)	650 (18,428)	926 (2,042)	1172 (2,584)
240D	3-60-460	2*	32.1	280	3	7.5	48	60	70	40.38 (3.75)	3	12000 (25,427)	650 (18,428)	926 (2,042)	1172 (2,584)
* - Tandem															
() Designates metric conversion															

# 3.0 UNIT SPECIFICATIONS



## 3.2 Electrical and Physical Data (cont.)

UNIT DIMENSIONS — (-)ACL2120 & (-)ACL2150 (10 & 12.5 TON)

CONTROL BOX END

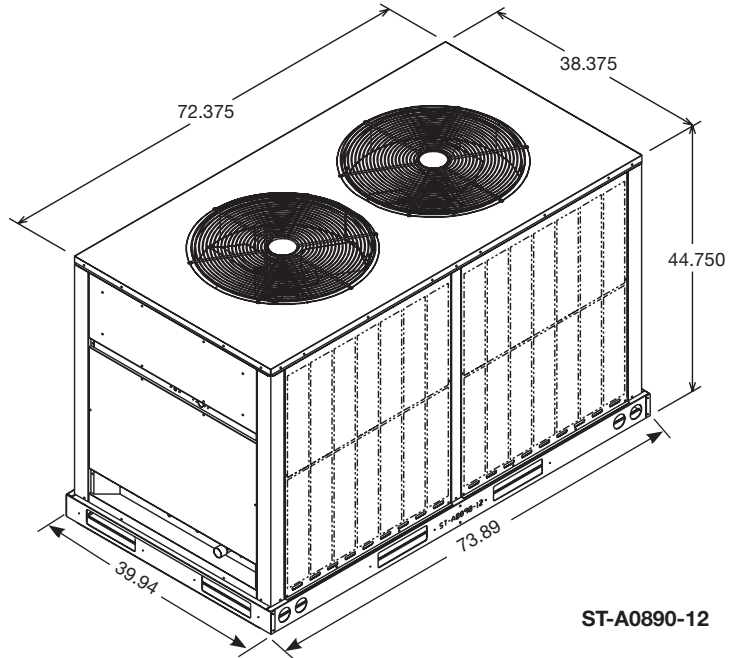
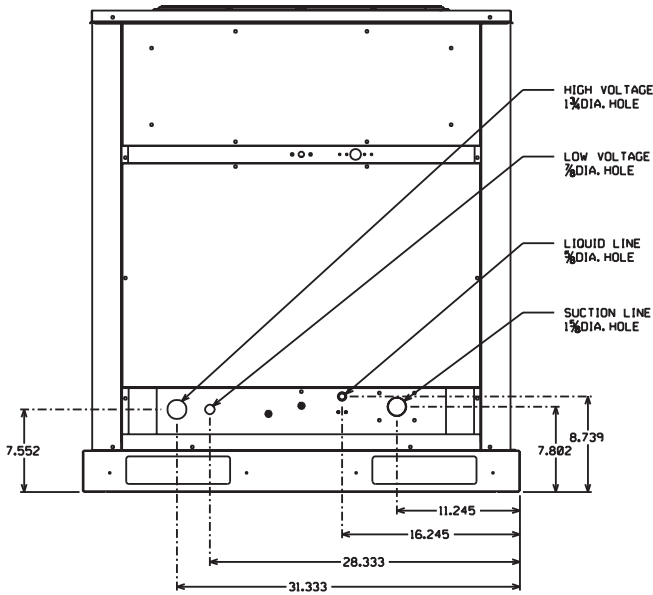

ST-A0890-12

BASE RAILS

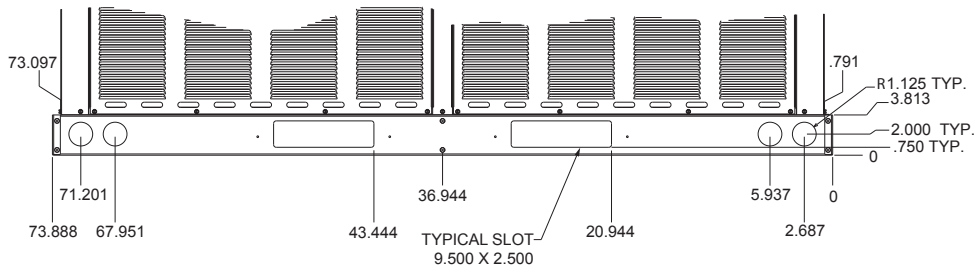

MIDDLE BASF RAIL  
BOTTOM

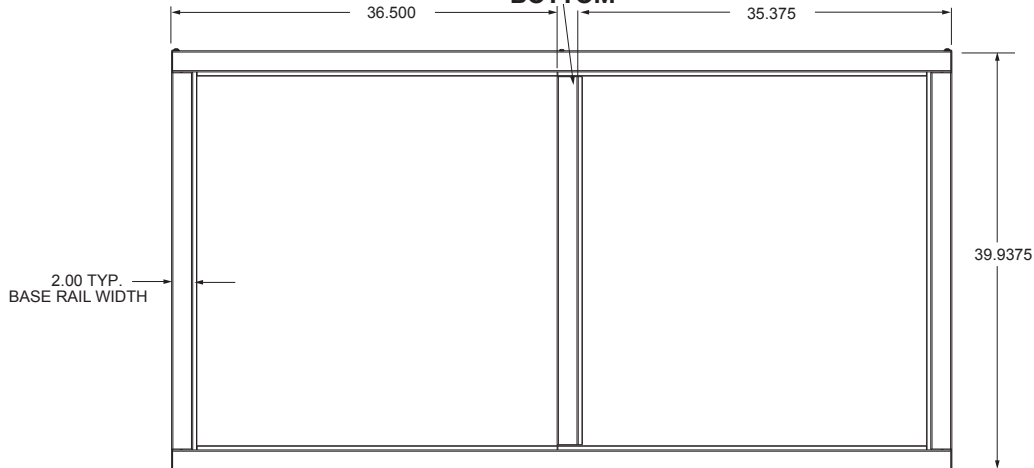

Specifications



# 3.0 UNIT SPECIFICATIONS



## 3.2 Electrical and Physical Data (cont.)

UNITS DIMENSIONS — (-)ACL2180 & (-)ACL2240 (15 & 20 TON)

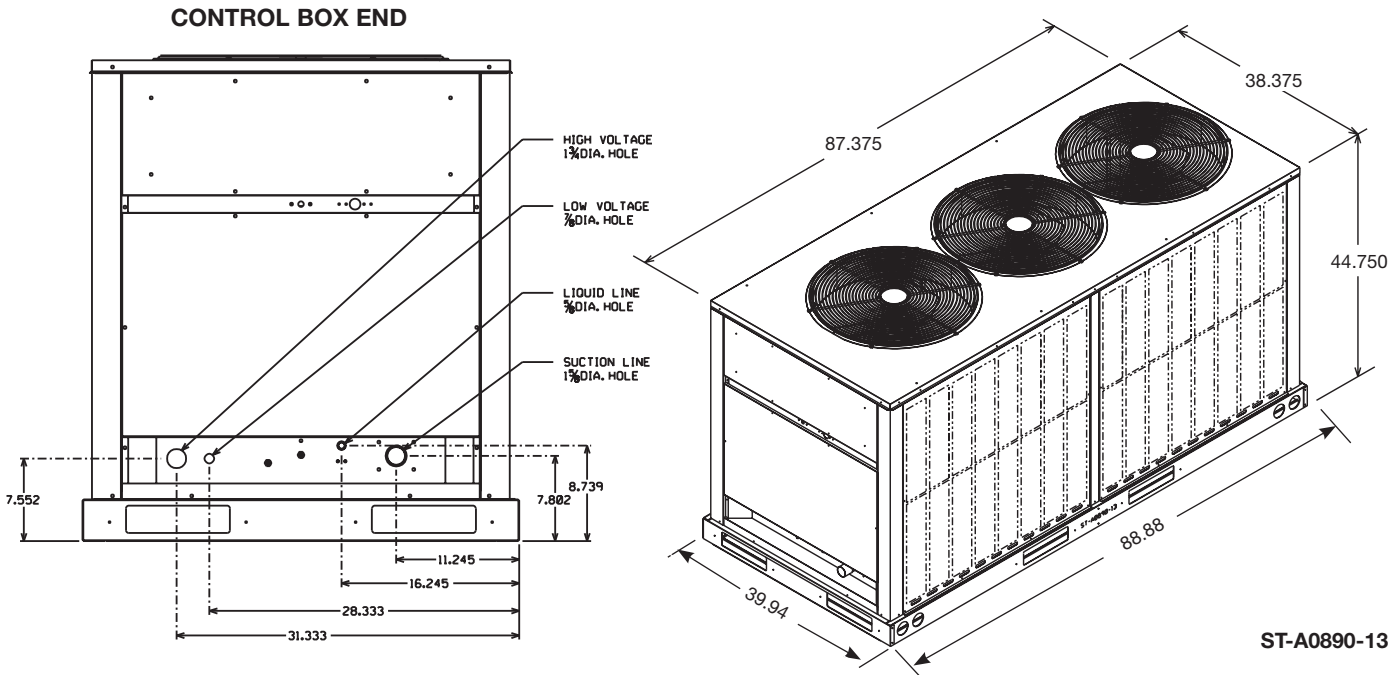

**BASE RAILS**

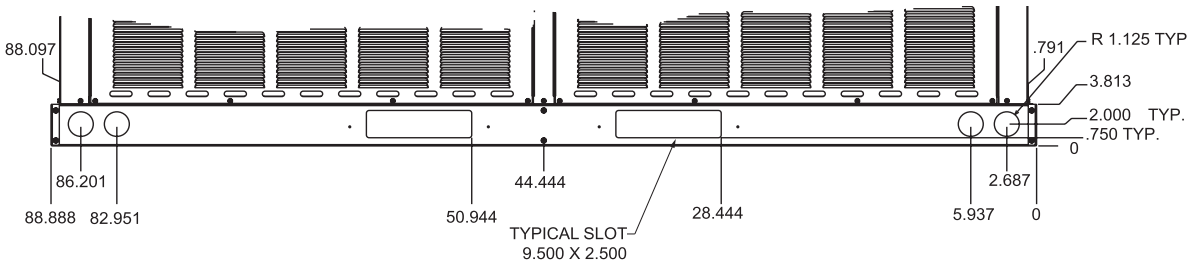

**BOTTOM**

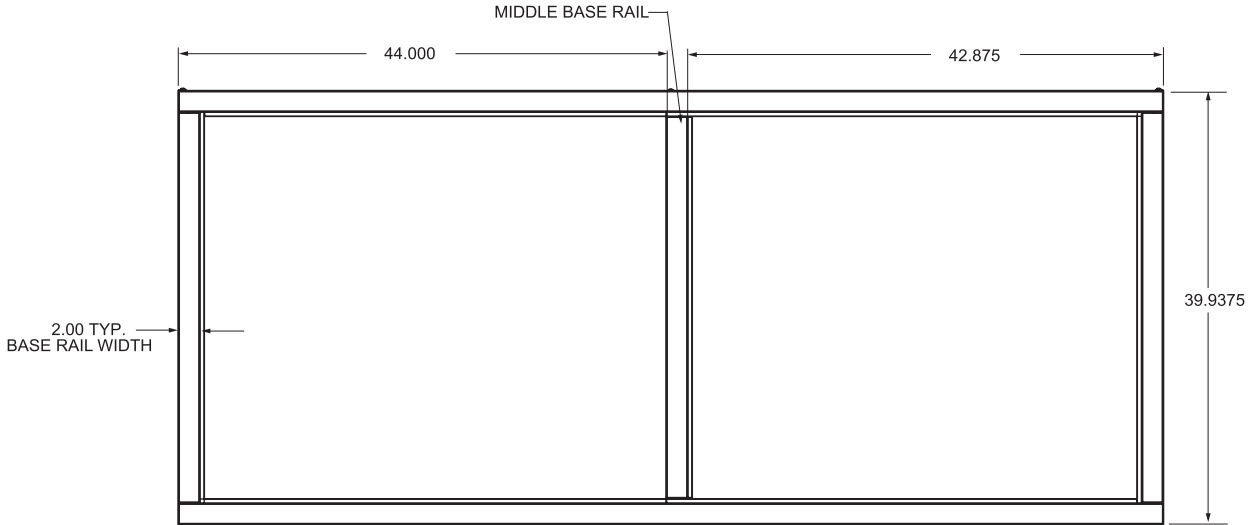

Specifications

# 3.0 UNIT SPECIFICATIONS



## 3.3 Unit Features

**CABINET** — Galvanized steel with a durable painted finish. Stamped louvered panels offer 100% protection for the condenser coil.

**COMPRESSOR** — The Scroll Compressor is hermetically sealed with internal overload protection and durable insulation on motor windings. The entire compressor is mounted on rubber grommets to reduce vibration and noise.

**CONDENSER COIL** — Constructed with copper tubes and aluminum fins mechanically bonded to the tubes for maximum heat transfer capabilities.

**BASE PAN** — Galvanized steel with powder coat paint finish.

**REFRIGERANT CONNECTIONS** — Field piping connections are made through a fixed panel. This allows complete access or removal of access panels after piping connections have been made.

**CRANKCASE HEATER** — Standard, all models. Prevents refrigerant migration to compressor(s).

**LOW AMBIENT CONTROL (OPTIONAL)** — A pressure sensitive fan cycling control to allow unit operation to 0°F if field installed.

**SERVICE VALVES** — Standard on liquid and suction lines. Allows outdoor section to be isolated from indoor coil.

**SERVICE ACCESS** — Control box as well as the compressor and other refrigerant controls being accessible through access panels. Control box may be open without affecting the normal operation of

the unit. Condenser fan motors are accessible by removing wire grilles.

**FILTER DRIER** — Standard (uninstalled) on all models. Helps ensure refrigerant cleanliness.

**TRANSFORMER** — Step down type, line to 24 volts. Provides control circuit voltage.

**CONTACTOR** — The contactor is an electrical switch which operates the compressor and condenser fans.

**HIGH PRESSURE CONTROL** — Opens the contactor circuit on high refrigerant pressure; automatic reset.

**LOW PRESSURE CONTROL** — Stops compressor operation in the event of loss of refrigerant.

**CONDENSER MOTOR** — All condensers utilize (ECM) Brushless permanent magnet motors.

**TESTING** — All units are run tested at the factory prior to shipment. Units are shipped with a holding charge of nitrogen.

**EXTERNAL GAUGE PORTS** — Allows pressures to be checked without removing access panel.

**COIL LOUVERS** — Helps prevent damage to outdoor coils.

**TIME DELAY** — Supplied on tandem compressor models to provide a delay between stages.

**EQUIPMENT GROUND** — Lug for field connecting of ground wire.

Specifications

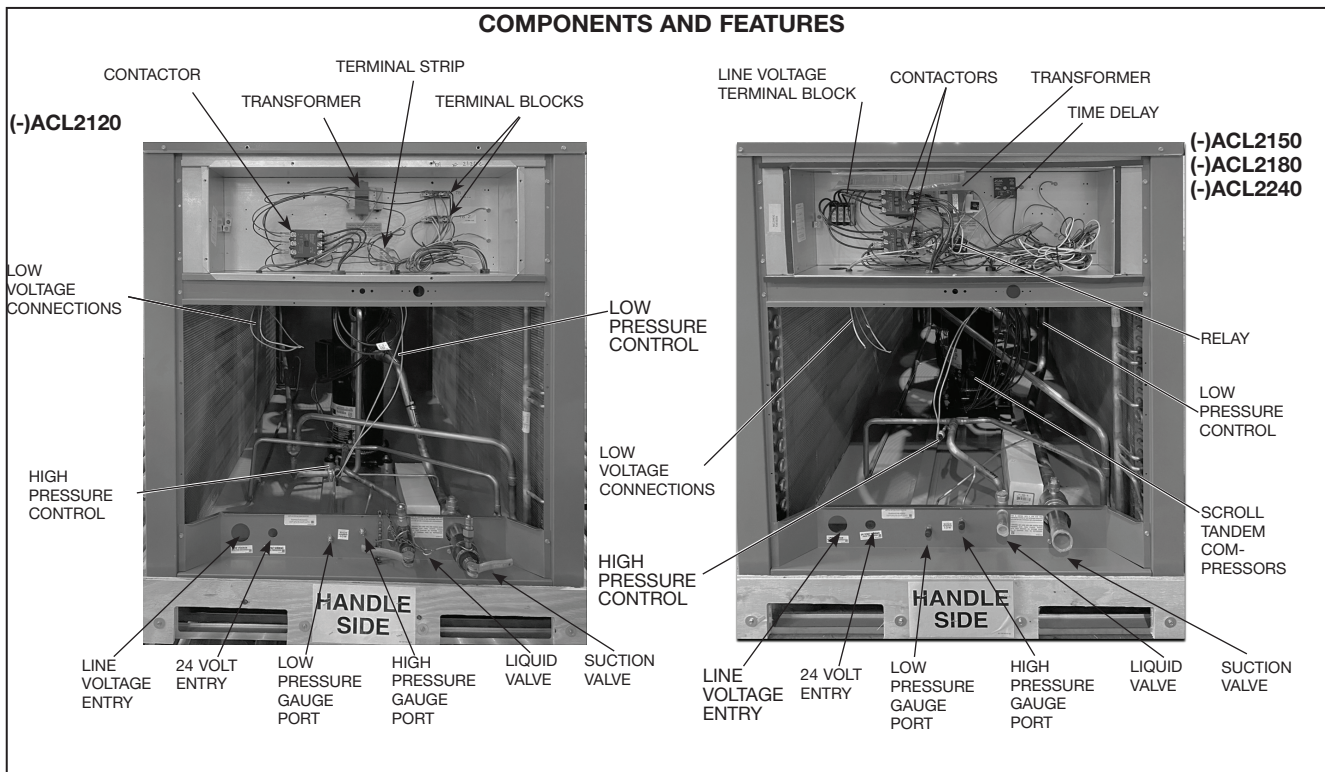

# 3.0 UNIT SPECIFICATIONS



## 3.3 Unit Features (Cont.)

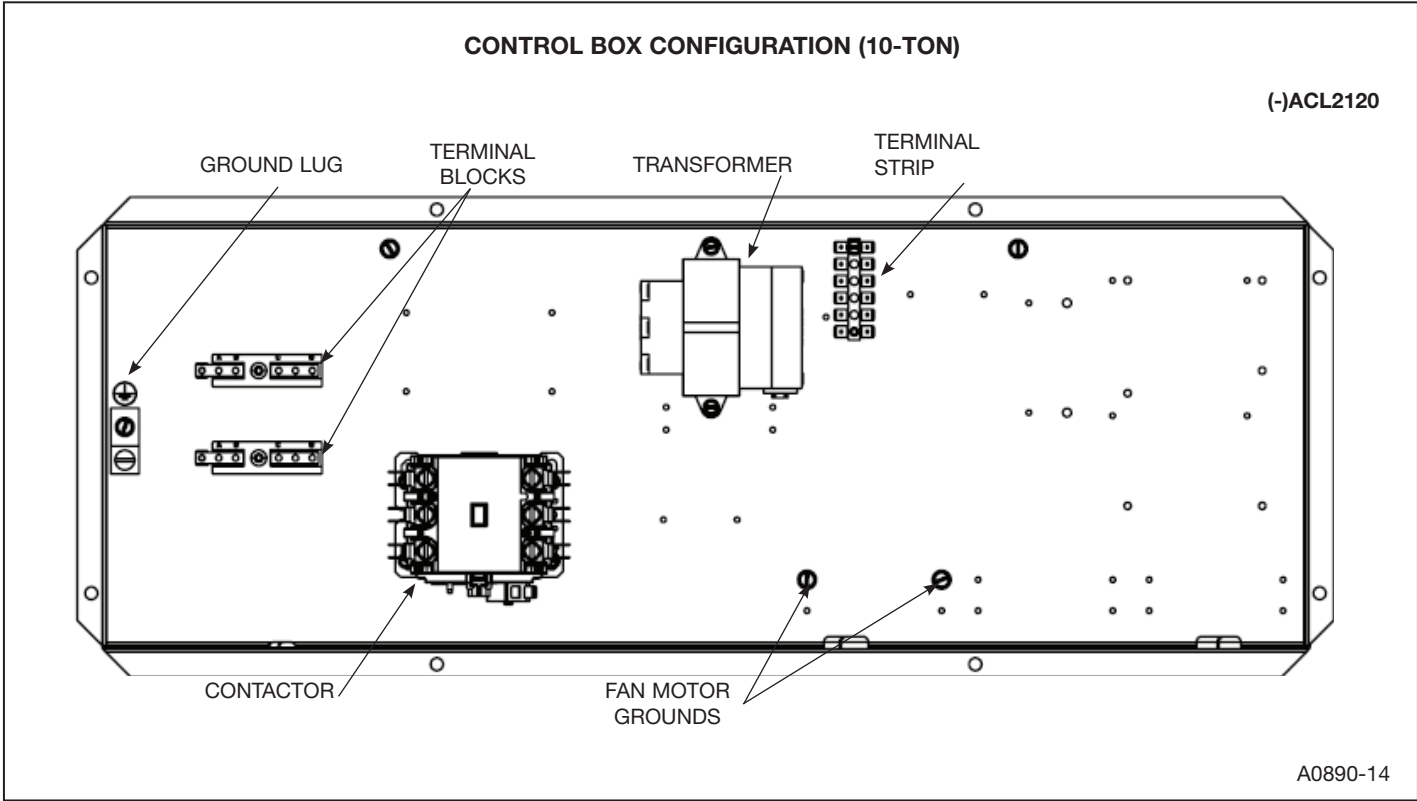

Specifications

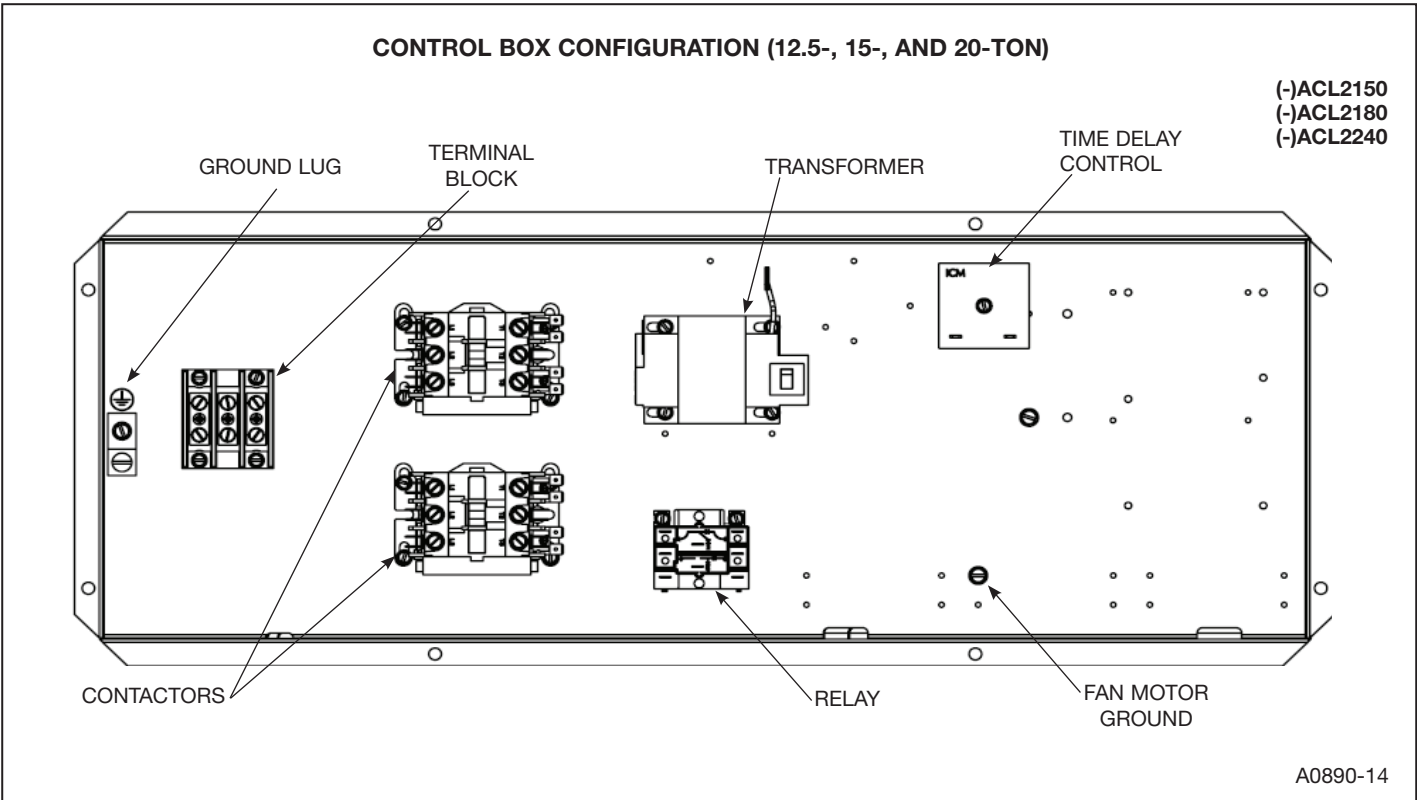

# 4.0 INSTALLATION



## 4.1 Tools and Refrigerant

### 4.1.1 Tools Required for Installing and Servicing R-410A Models

Manifold Sets:

- Up to 800 PSIG High-Side
- Up to 250 PSIG Low-Side
- 550 PSIG Low-Side Retard

Manifold Hoses:

- Service Pressure Rating of 800 PSIG

Recovery Cylinders:

- 400 PSIG Pressure Rating
- Dept. of Transportation 4BA400 or BW400

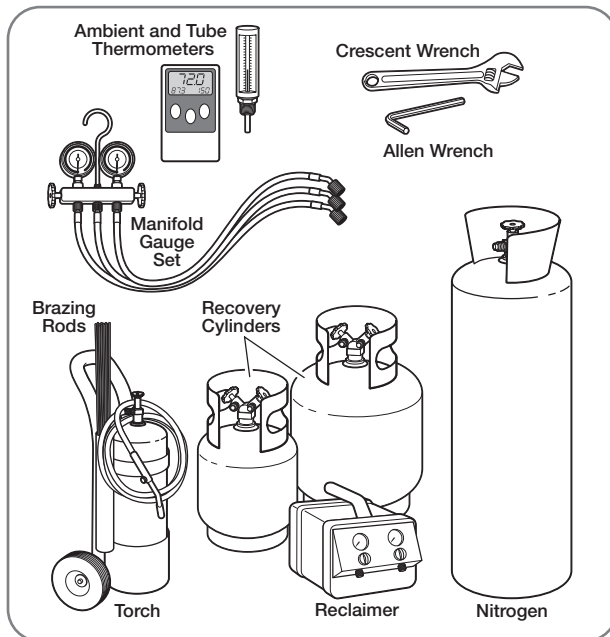

**CAUTION:** R-410A systems operate at higher pressures than R-22 systems. Do not use R-22 service equipment or components on R-410A equipment.

### 4.1.2 Specifications of R-410A

**Application:** R-410A is not a drop-in replacement for R-22. Equipment designs must accommodate its higher pressures. It cannot be retrofitted into R-22 heat pumps.

**Physical Properties:** R-410A has an atmospheric boiling point of  $-62.9^{\circ}\text{F}$  [ $-52.7^{\circ}\text{C}$ ] and its saturation pressure at  $77^{\circ}\text{F}$  [ $25^{\circ}\text{C}$ ] is 224.5 psig.

**Composition:** R-410A is a near-azeotropic mixture of 50% by weight difluoromethane (HFC-32) and 50% by weight pentafluoroethane (HFC-125).

**Pressure:** The pressure of R-410A is approximately 60% (1.6 times) greater than R-22. Recovery and recycle equipment, pumps, hoses, and the like must have design pressure ratings appropriate for R-410A. *Manifold sets need to range up to 800 psig high-side and 250 psig low-side with a 550 psig low-side retard. Hoses need to have a service pressure rating of 800 psig. Recovery cylinders need to have a 400 psig service pressure rating, DOT 4BA400 or DOT BW400.*

**Combustibility:** At pressures above 1 atmosphere, a mixture of R-410A and air can become combustible. R-410A and air should never be mixed in tanks or supply lines or be allowed to accumulate in storage tanks. Leak checking should never be done with a mixture of R-410A and air. Leak-checking can be performed safely with nitrogen or a mixture of R-410A and nitrogen.

### 4.1.3 Quick-Reference Guide for R-410A

- R-410A refrigerant operates at approximately 60% higher pressure (1.6 times) than R-22. Ensure that servicing equipment is designed to operate with R-410A.
- R-410A refrigerant cylinders are light rose in color.
- R-410A, as with other HFCs, is only compatible with POE oils.
- Vacuum pumps will not remove moisture from POE oil used in R-410A systems.
- R-410A systems are to be charged with liquid refrigerants. Prior to March 1999, R-410A refrigerant cylinders had a dip tube. These cylinders should be kept upright for equipment charging. Post-March 1999 cylinders do not have a dip tube and should be inverted to ensure liquid charging of the equipment.
- Do not install a suction line filter drier in the liquid line.
- A factory-approved biflow liquid line filter drier is shipped with every unit and must be installed in the liquid line at the time of installation. Only manufacturer-approved liquid line filter driers can be used. These are Sporlan (CW083S) and Alco (80K083S) driers. These filter driers are rated for minimum working pressure of 600 psig. The filter drier will only have adequate moisture-holding capacity if the system is properly evacuated.
- Desiccant (drying agent) must be compatible for POE oils and R-410A refrigerant.

# 4.0 INSTALLATION



## 4.2 Choosing a Location

### 4.2.1 Allowable Clearances

- 24" [61.0 cm] to side intake louvers
- 24" [61.0 cm] between multiple units
- 36" [91.4 cm] to service access panels
- 60" [152.4 cm] vertical for fan discharge

**IMPORTANT:** Consult local and national building codes and ordinances for special installation requirements. Following location information will provide longer life and simplified servicing of the outdoor unit.

**NOTICE:** These units must be installed outdoors. No ductwork can be attached, or other modifications made, to the discharge grille. Modifications will affect performance or operation.

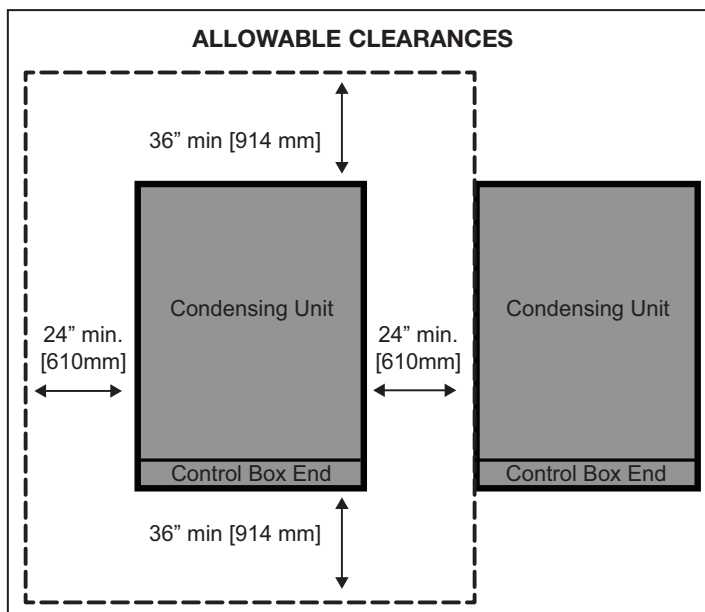

### 4.2.2 Operational Issues Related to Unit Location

**IMPORTANT:** Locate the unit in a manner that will not prevent, impair, or compromise the performance of other equipment installed in proximity to the unit. Maintain all required minimum distances to gas and electric meters, dryer vents, and exhaust and inlet openings. In the absence of national codes or manufacturers' recommendations, local code recommendations and requirements will take precedence.

- Refrigerant piping and wiring should be properly sized and kept as short as possible to avoid capacity losses and increased operating costs.
- Locate the unit where water runoff will not create a problem with the equipment. Position the unit away from the drip edge of the roof whenever possible. Units are weatherized, but can be affected by the following:
- Water pouring into the unit from the junction of rooflines, without protective guttering. Large volumes of water entering the unit while in operation can impact fan blade or motor life.
- Closely follow the clearance recommendations in section 4.2.1.

# 4.0 INSTALLATION



## 4.2 Choosing a Location (cont.)

### 4.2.3 Corrosive Environment

The metal parts of this unit may be subject to rust or deterioration if exposed to a corrosive environment. This oxidation could shorten the equipment's useful life.

Corrosive elements include, but are not limited to, salt spray, fog or mist in seacoast areas, sulphur or chlorine from lawn watering systems, and various chemical contaminants from industries such as paper mills and petroleum refineries.

If the unit is to be installed in an area where contaminants are likely to be a problem, special attention should be given to the equipment location and exposure.

- Avoid having lawn sprinkler heads spray directly on the unit cabinet.
- In coastal areas, locate the unit on the side of the building away from the waterfront.
- Shielding provided by a fence or shrubs may give some protection, but cannot violate minimum airflow and service access clearances.

**⚠ WARNING:** Disconnect all power to unit before starting maintenance. Failure to do so can cause electrical shock resulting in severe personal injury or death.

Regular maintenance will reduce the buildup of contaminants and help to protect the unit's finish.

- Frequent washing of the cabinet, fan blade, and coil with fresh water will remove most of the salt or other contaminants that build up on the unit.
- Regular cleaning and waxing of the cabinet with a good automobile polish will provide some protection.
- A good liquid cleaner may be used several times a year to remove matter that will not wash off with water.

### 4.2.4 Customer Satisfaction Issues

- The outdoor unit should be located away from areas where noise from the unit would be considered objectionable.
- To prevent noise transmission, the mounting pad for the outdoor unit should not be connected to the structure and should be located a sufficient distance above grade to prevent ground water from entering the unit.

Location



## 4.3 Mounting Unit

### 4.3.1 Corner Weights and Rigging

For lifting unit into place, rig it as shown in the illustration below, making certain that the rigging slings are of sufficient length to maintain equilibrium of the unit when it is being lifted. Before placing the unit on the roof, make certain that the roof structure has adequate strength to support the weight of the unit. Corner weights are provided in the table below.

Mounting

# 4.0 INSTALLATION

## ROOFTOP INSTALLATION – RIGGING

### CORNER WEIGHTS – POUNDS

Model	Total Weight Lbs[kg]	Corner Weights LBS[kg]			
		A	B	C	D
(-)ACL2120	565[256]	97[44]	181[82]	215[98]	73[33]
(-)ACL2150	647[293]	189[86]	157[71]	161[73]	139[63]
(-)ACL2180	832[377]	240[109]	183[83]	167[6]	242[110]
(-)ACL2240	926[420]	308[140]	128[58]	161[73]	328[149]

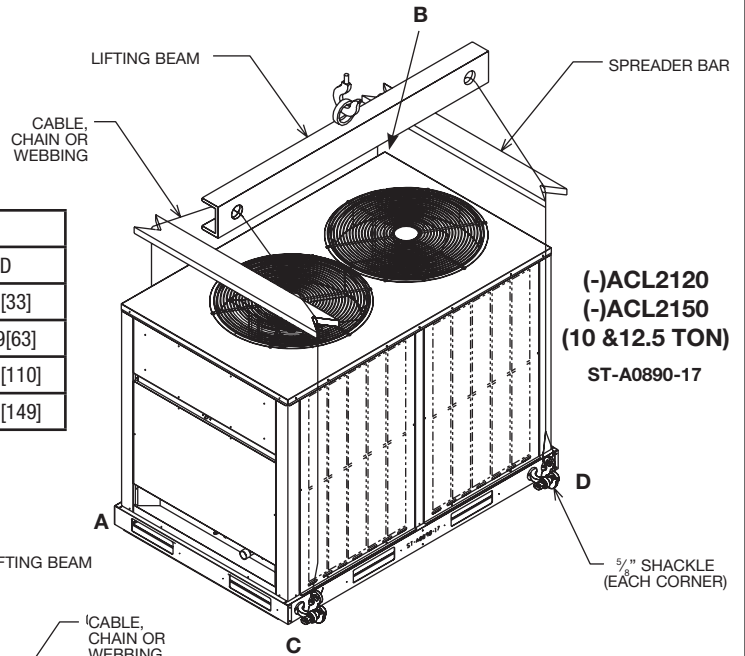

(-)ACL2120  
(-)ACL2150  
(10 & 12.5 TON)  
ST-A0890-17

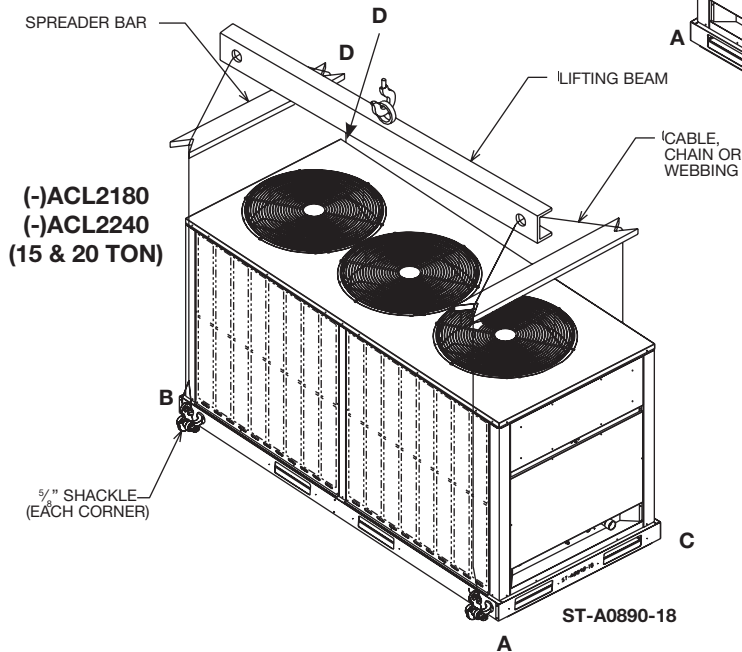

(-)ACL2180  
(-)ACL2240  
(15 & 20 TON)

ST-A0890-18

### 4.3.2 High Wind and Seismic Tie-Down Methods

The manufacturer-approved/recommended method is a guide to securing equipment for wind and seismic loads. Other methods might provide the same result, but the manufacturer method is the only one endorsed by the manufacturer for securing equipment where wind or earthquake damage can occur. Additional information is available on the manufacturer's website or from the wholesale distributor.

### 4.3.3 Elevating Unit

**⚠ WARNING:** Secure an elevated unit and its elevating stand in order to prevent tipping. Failure to do so may result in severe personal injury or death.

If elevating a unit on a flat roof, use 4" x 4" [10.2 cm x 10.2 cm] or equivalent stringers positioned to distribute unit weight evenly and prevent noise and vibration.

**NOTICE:** Do not block drain openings on bottom of unit.

# 4.0 INSTALLATION



## 4.4 Refrigerant Line Set Selection

### 4.4.1 Replacing Existing Systems

To prevent failure of a new unit, the existing line set must be correctly sized for the new unit and must be cleaned or replaced. Care must be taken so the expansion device is not plugged. For new and replacement units, a liquid line filter drier must be installed and the line set must be properly sized. Test the oil for acid. If it tests positive for acid, a suction line filter drier is mandatory.

**IMPORTANT:** When replacing an R-22 unit with an R-410A unit, either replace the line set or ensure that residual mineral oil is drained from existing lines including oil trapped in low spots.

### 4.4.2 Line Set Length and Fitting Losses

Refrigerant tubing is measured in terms of actual length and equivalent length. Actual length is used for refrigerant charge applications. Equivalent length takes into account pressure losses from

tubing length, fittings, vertical separation, accessories, and filter driers. The table below references commonly used equivalent lengths.

Table 1

Equivalent Length for Fittings (ft) [m]						
Line Size (in) [mm]	90° Short Radius Elbow	90° Long Radius Elbow	45° Elbow	Solenoid Valve	Site Glass	Filter Drier
1/2 [12.71]	1.4 [0.43]	0.9 [0.27]	0.4 [0.12]	9 [2.74]	0.6 [0.18]	6 [1.83]
5/8 [15.88]	1.5 [0.46]	1 [0.30]	0.5 [0.15]	12 [3.66]	0.8 [0.24]	6 [1.83]
3/4 [19.05]	1.9 [0.58]	1.3 [0.40]	0.6 [0.18]	14 [4.27]	0.9 [0.27]	6 [1.83]
7/8 [22.23]	2.3 [0.70]	1.5 [0.46]	0.7 [0.21]	15 [4.57]	1.0 [0.30]	6 [1.83]
1-1/8 [28.58]	2.7 [0.82]	1.8 [0.55]	0.9 [0.27]	22 [6.71]	N/A	N/A
1-3/8 [34.93]	3.6 [1.10]	2.4 [0.73]	1.2 [0.37]	28 [8.53]	N/A	N/A
1-5/8 [44.28]	4.2 [1.28]	2.8 [0.85]	1.4 [0.43]	35 [10.67]	N/A	N/A
2-1/8 [53.98]	5.9 [1.80]	3.9 [1.19]	1.8 [0.55]	45 [13.72]	N/A	N/A

### 4.4.3 Liquid Line Selection

The purpose of the liquid line is to transport warm sub-cooled liquid refrigerant between the outdoor unit to the indoor unit. It is important not to allow the refrigerant to flash into superheated vapor prior to the expansion device of the indoor coil. The flashing of refrigerant can occur for the following reasons:

- Low refrigerant charge
- Improperly selected liquid line size
- Absorption of heat prior to expansion device
- Excessive vertical separation between the outdoor unit and indoor coil
- Restricted liquid line or filter drier
- Kinked liquid line

Table 2 lists the equivalent length per 25' of liquid line at various diameters up to 250' [76 m]. The total pressure drop allowed for the liquid line is 50 PSI [345 kPa]. The procedure for selecting the proper liquid line is as follows:

- Measure the total amount of vertical separation between the outdoor unit and indoor coil.
- Measure the linear length of liquid line needed.
- Add all of the equivalent lengths associated with any fittings or accessories using Table 1 above.
- Add the linear length to the total fitting equivalent length. This will equal your total equivalent line length.
- Reference Table 2 to verify the calculated equivalent length is acceptable with the required vertical separation and diameter of liquid line.



# 4.0 INSTALLATION



## 4.4 Refrigerant Line Set Selection (cont.)

TABLE 2

10 - 20 Ton Air-Conditioners (English Units)												
Unit Size	Allowable Liquid Line Size	Allowable Suction Line Size	Equivalent Length (Feet)									
			< 25	26-50	51-75	76-100	101-125	126-150	151-175	176-200	201-225	226-250
			Maximum Vertical Rise (Outdoor Unit Below Indoor Unit) * / Capacity Multiplier									
10 Ton	5/8"	1-3/8"	25 / 1.00	50 / 1.00	75 / 0.99	100 / 0.99	102 / 0.99	99 / 0.99	96 / 0.98	93 / 0.98	90 / 0.98	87 / 0.97
	5/8"	1-5/8"	25 / 1.00	50 / 1.00	75 / 1.00	100 / 1.00	102 / 1.00	99 / 1.00	96 / 0.99	93 / 0.99	90 / 0.99	87 / 0.99
12.5 Ton	5/8"	1-3/8"	25 / 1.00	50 / 1.00	75 / 0.99	99 / 0.99	94 / 0.98	89 / 0.98	84 / 0.97	78 / 0.97	73 / 0.96	68 / 0.96
	5/8"	1-5/8"	25 / 1.00	50 / 1.00	75 / 1.00	99 / 1.00	94 / 0.99	89 / 0.99	84 / 0.99	78 / 0.99	73 / 0.98	68 / 0.98
15 Ton	5/8"	1-5/8"	25 / 1.00	50 / 1.00	75 / 0.99	89 / 0.99	82 / 0.99	74 / 0.99	66 / 0.98	59 / 0.98	51 / 0.98	43 / 0.97
	3/4"	1-5/8"	25 / 1.00	50 / 1.00	75 / 0.99	100 / 0.99	105 / 0.99	102 / 0.99	99 / 0.98	96 / 0.98	93 / 0.98	90 / 0.97
	5/8"	2-1/8"	25 / 1.00	50 / 1.00	75 / 1.00	89 / 1.00	82 / 1.00	74 / 1.00	66 / 1.00	59 / 1.00	51 / 0.99	43 / 0.99
	3/4"	2-1/8"	25 / 1.00	50 / 1.00	75 / 1.00	100 / 1.00	105 / 1.00	102 / 1.00	99 / 1.00	96 / 1.00	93 / 0.99	90 / 0.99
20 Ton	7/8"	1-5/8"	25 / 1.00	50 / 1.00	75 / 0.99	100 / 0.99	110 / 0.98	108 / 0.98	106 / 0.97	103 / 0.97	101 / 0.96	99 / 0.96
	7/8"	2-1/8"	25 / 1.00	50 / 1.00	75 / 1.00	100 / 1.00	110 / 1.00	108 / 1.00	106 / 1.00	103 / 1.00	101 / 0.99	99 / 0.99

10 - 20 Ton Air-Conditioners (Metric Units)												
Unit Size	Allowable Liquid Line Size	Allowable Suction Line Size	Equivalent Length (Meters)									
			< 8	8-15	16-23	24-30	31-38	39-46	47-53	54-61	62-69	70-76
			Maximum Vertical Rise (Outdoor Unit Below Indoor Unit) * / Capacity Multiplier									
10 Ton	5/8"	1-3/8"	8 / 1.00	15 / 1.00	23 / 0.99	30 / 0.99	31 / 0.99	30 / 0.99	29 / 0.98	28 / 0.98	27 / 0.98	27 / 0.97
	5/8"	1-5/8"	8 / 1.00	15 / 1.00	23 / 1.00	30 / 1.00	31 / 1.00	30 / 1.00	29 / 0.99	28 / 0.99	27 / 0.99	27 / 0.99
12.5 Ton	5/8"	1-3/8"	8 / 1.00	15 / 1.00	23 / 0.99	30 / 0.99	29 / 0.98	27 / 0.98	26 / 0.97	24 / 0.97	22 / 0.96	21 / 0.96
	5/8"	1-5/8"	8 / 1.00	15 / 1.00	23 / 1.00	30 / 1.00	29 / 0.99	27 / 0.99	26 / 0.99	24 / 0.99	22 / 0.98	21 / 0.98
15 Ton	5/8"	1-5/8"	8 / 1.00	15 / 1.00	23 / 0.99	27 / 0.99	25 / 0.99	23 / 0.99	20 / 0.98	18 / 0.98	16 / 0.98	13 / 0.97
	3/4"	1-5/8"	8 / 1.00	15 / 1.00	23 / 0.99	30 / 0.99	32 / 0.99	31 / 0.99	30 / 0.98	29 / 0.98	28 / 0.98	27 / 0.97
	5/8"	2-1/8"	8 / 1.00	15 / 1.00	23 / 1.00	27 / 1.00	25 / 1.00	23 / 1.00	20 / 1.00	18 / 1.00	16 / 0.99	13 / 0.99
	3/4"	2-1/8"	8 / 1.00	15 / 1.00	23 / 1.00	30 / 1.00	32 / 1.00	31 / 1.00	30 / 1.00	29 / 1.00	28 / 0.99	27 / 0.99
20 Ton	7/8"	1-5/8"	8 / 1.00	15 / 1.00	23 / 0.99	30 / 0.99	34 / 0.98	33 / 0.98	32 / 0.97	31 / 0.97	31 / 0.96	30 / 0.96
	7/8"	2-1/8"	8 / 1.00	15 / 1.00	23 / 1.00	30 / 1.00	34 / 1.00	33 / 1.00	32 / 1.00	31 / 1.00	31 / 0.99	30 / 0.99

Notes:

- 1) Do not exceed 200 ft [61 m] linear line length.
- 2) \* Do not exceed 100 ft [30 m] vertical separation if outdoor unit is above indoor unit.
- 3) Always use the smallest liquid line allowable to minimize refrigerant charge.
- 4) Applications shaded in light gray indicate capacity multipliers between 0.90 and 0.96 which are not recommended, but are allowed.

**Example:** A 10 ton condensing unit is installed 50' below the indoor unit, requires 75' of 5/8" diameter liquid line, 1-3/8" diameter suction line, and 4 90° LR elbows, and a filter drier.

This application is acceptable because the 50' vertical rise is less than the maximum rise of 100' for this application.

- Filter Drier Equivalent Length (ft.) = 6'
- Fitting Equivalent Length (ft.) = 4 × 1' = 3.6'
- Total Equivalent Length (ft.) = 75' + 6' + 4' = 85'

Unit Size	Allowable Liquid Line Size	Allowable Suction Line Size	Equivalent Length (Feet)									
			< 25	26-50	51-75	76-100	101-125	126-150	151-175	176-200	201-225	226-250
			Maximum Vertical Rise (Outdoor Unit Below Indoor Unit) * / Capacity Multiplier									
10 Ton	5/8"	1-3/8"	25 / 1.00	50 / 1.00	75 / 0.99	100 / 0.99	102 / 0.99	99 / 0.99	96 / 0.98	93 / 0.98	90 / 0.98	87 / 0.97
	5/8"	1-5/8"	25 / 1.00	50 / 1.00	75 / 1.00	100 / 1.00	102 / 1.00	99 / 1.00	96 / 0.99	93 / 0.99	90 / 0.99	87 / 0.99

(Excerpt from Table 2)

# 4.0 INSTALLATION



## 4.4 Refrigerant Line Set Selection (cont.)

### 4.4.4 Suction Line Selection

Purpose of the vapor line is to return superheated vapor to the condensing unit from the evaporator. Proper suction line sizing is important because it plays an important role in returning oil to the compressor to prevent potential damage to the bearings, valves, and scroll sets. Also, an undersized suction line can dramatically reduce capacity and performance of the system. The procedure for selecting the proper suction line is as follows:

- Determine the total linear length of suction line required.
- Add all of the equivalent lengths associated with any fittings or accessories using the table on previous page.
- Add the linear length and total fitting equivalent length. This will equal your total equivalent length.
- Reference Table 2 to verify that the calculated equivalent length falls within the acceptable region of the chart.
- Verify the capacity difference is compatible with the application using the multiplier in Table 2.
- Use only suction line sizes listed in Table 2.

### 4.4.5 Long Line Set Considerations

Generally, installations with actual (linear) line set lengths over 80 ft. [24 m] or vertical separation between the outdoor and indoor units exceed 20 ft. [6 m] are considered long line length applications and require special considerations to maintain good performance and compressor reliability. The following things should be considered when installing a system with a long line set length.

- Additional refrigerant charge
- Fitting losses and maximum equivalent length considerations
- Refrigerant migration during the off cycle
- Oil return to the compressor
- Capacity losses
- Additional oil

#### 4.4.5.1 Oil Return to Compressor

Small amounts of compressor crankcase oil is picked up and carried out of the compressor by the moving refrigerant and is circulated through the system along with the refrigerant before it returns to the compressor crankcase. It is critical to the life of the compressor for the oil to be able to return to the compressor to maintain an adequate level of oil in the compressor crankcase. Oversized vapor lines result in inadequate refrigerant velocities

to carry the oil along with the refrigerant and will cause the oil to accumulate in the low spots in the vapor line instead of being returned to the compressor crankcase. This is especially true for long line lengths. Only use the vapor line sizes listed in Table 2 to assure proper oil return. Do not oversize the vapor line.

#### 4.4.5.2 Refrigerant Migration During Off Cycle

Long line set applications can require a considerable amount of additional refrigerant. This additional refrigerant must be managed throughout the entire outdoor ambient operating range that the system will experience throughout its life cycle. Off-cycle refrigerant migration is where refrigerant condenses and migrates to the coldest and/or lowest part of the system. Excessive build-up of refrigerant near or inside the compressor can result in poor reliability and noisy operation during start-up. Long line set applications require a non-bleed TXV on the indoor coil and a crankcase heater. All models related to this manual have a crankcase heater from the factory and all AHRI matched indoor units have a non-bleed TXV. If only the condensing unit is being replaced, it is important to confirm that the indoor coil has a non-bleed TXV. If it doesn't, a liquid line solenoid valve must be installed near the indoor coil with the flow arrow pointing toward the indoor coil.

#### 4.4.5.3 Maximum Liquid Pressure Drop

The total liquid line pressure drop must not exceed 50 psig [345 kPa] to assure a solid column of liquid at the metering device and stable control of superheat. Be sure to account for vertical separation, elbows, filter driers, solenoid valves, sight glasses, and check valves when calculating liquid line pressure drop.

#### 4.4.5.4 Liquid Line Refrigerant Flashing

Excessive pressure drop and heat gain in long liquid lines can result in the refrigerant flashing into a vapor before it reaches the metering device which will dramatically reduce the capacity and efficiency of the system. For this reason, the liquid line must be sized properly using Table 2 and must be insulated in unconditioned spaces.

# 4.0 INSTALLATION



## 4.4 Refrigerant Line Set Selection (cont.)

### 4.4.5.5 Compressor Oil Level Adjustment

Additional oil will need to be added for long line set applications. Below is the equation for the oil level adjustment. The compressor name plate oil charge for the different outdoor units is shown in the table below.

### 4.4.5.6 Capacity Losses

Long line lengths can result in a reduction in capacity due to suction line pressure drop and heat gain. Refer to Table 2 for capacity loss multipliers for various vapor line diameters and lengths. Only use vapor lines listed in Table 2 to assure proper oil return. This table does not account for any capacity loss due to heat gain from the environment. It is extremely important not to oversize the suction line to minimize capacity loss at the expense of proper oil return. The full length of the suction line must be insulated to minimize heat gain.

TABLE 3

MODEL	Compressor Nameplate Oil Charge	Oil Type
(-)ACL2120	85 fl. oz. [2514 ml]	3MAF POE
(-)ACL2150	102 fl. oz. [3017 ml]	3MAF POE
(-)ACL2180	127 fl. oz. [3756 ml]	3MAF POE
(-)ACL2240	170 fl. oz. [5028 ml]	3MAF POE

**Oil to be Added** = [(Refrigerant Charge Adjustment (oz.) + OD Unit Refrigerant Name Plate Charge (oz.)) × (0.022)] – [(0.10) × (Compressor Name Plate Oil Charge (oz.))]

#### Example:

An application for an (-)ACL2120 requires 125 ft. of line set with a liquid line diameter of 5/8" and a suction line diameter of 1-3/8", Charge Adjustment = 125 ft. × (1.65 oz/ft + 0.34 oz/ft) = 248.75 oz., (see "System Start-Up & Refrigerant Charging")

Name Plate Refrigerant Charge = 422 oz.,

Compressor Name Plate Oil Charge = 85 oz.,

Oil to be Added = ((248.75 oz. + 422 oz.) × .022) – (.10 × 85 oz.) = 6.3 oz.

# 4.0 INSTALLATION



## 4.5 Line Set Installation

- If tubing is to be run underground, it must be run in a sealed watertight chase.
- Use care in routing tubing and do not kink or twist. Use a good quality tubing bender on the vapor line to prevent kinking.

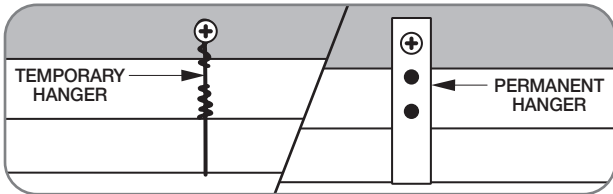

- Route the tubing using temporary hangers; then straighten the tubing and install permanent hangers. The tubing must be adequately

supported.

- Isolate the vapor line from the building structure. If the vapor line comes in contact with inside walls, ceiling, or flooring, the vibration of the vapor line in the heating mode will result in noise inside the structure.
- Blow out the liquid and vapor lines with dry nitrogen before connecting to the outdoor unit and indoor coil to remove debris that can plug the expansion device.

### 4.5.1 Important Tubing Installation Practices

Observe the following when installing correctly sized type “L” refrigerant tubing between the outdoor unit and indoor coil:

- Check Table 2 for the correct suction line size and liquid line size.
- **If a portion of the liquid line passes through a very hot area where liquid refrigerant can be heated to form vapor, insulating the liquid line is required.**
- Use clean, dehydrated, sealed refrigeration-grade tubing.
- Always keep tubing sealed until tubing is in place and connections are to be made.
- A high-quality filter drier is included with all units and must be installed in the liquid line upon unit installation.
- When replacing an R-22 system with an R-410A system and the line set is not replaced, blow out the lines with dry nitrogen to remove as much of the remaining mineral oil as possible. Check for low spots where oil may be trapped and take measures to drain the oil from those areas.

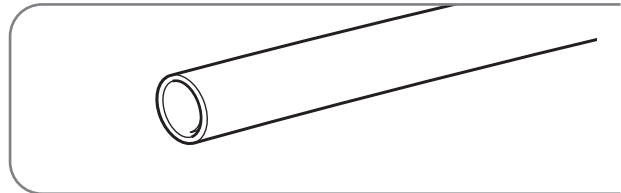

- If tubing has been cut, deburr the ends while holding the tubing in a position to prevent chips from falling into tubing. Burrs such as those caused by tubing cutters can affect performance dramatically, particularly on small diameter liquid lines.
- For best operation, keep tubing run as short as possible with a minimum number of elbows or bends.
- Locations where the tubing will be exposed to mechanical damage should be avoided. If it is necessary to use such locations, the copper tubing should be protected by a housing to prevent damage.

# 4.0 INSTALLATION



## 4.5 Line Set Installation (cont.)

### 4.5.2 Relative Location of Indoor and Outdoor Units

#### 4.5.2.1 Indoor and Outdoor Unit Near Same Level

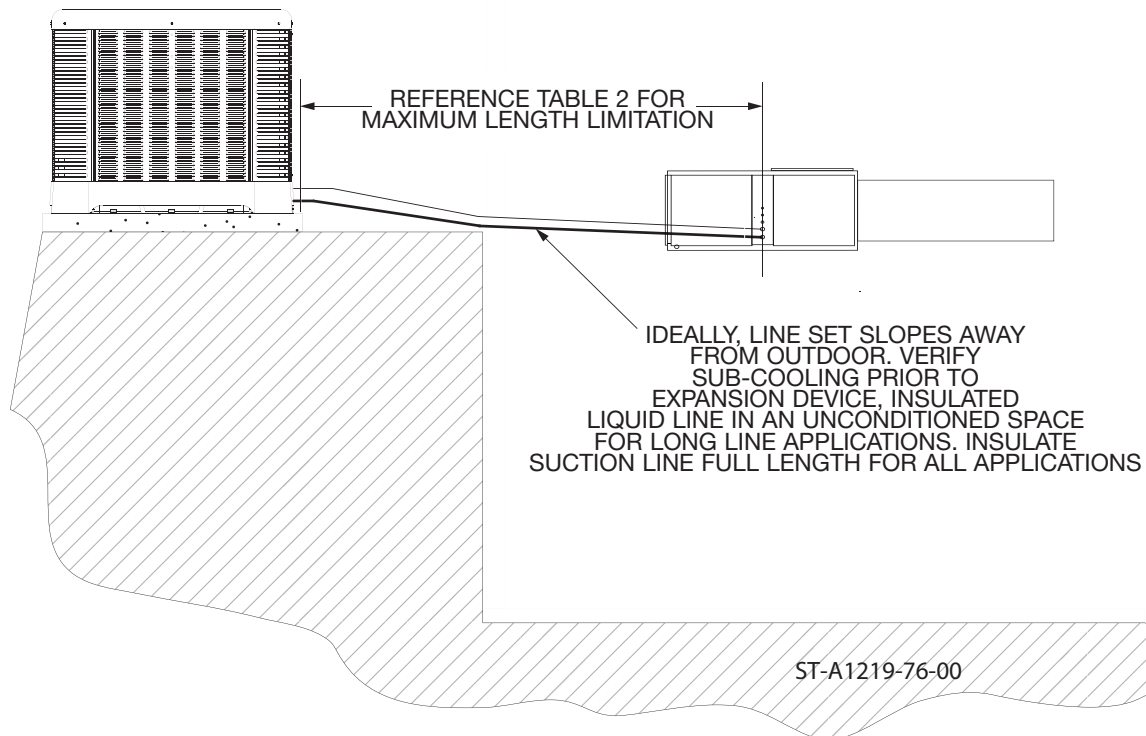

For applications that are considered to have a long line set with the outdoor unit and indoor unit near the same level the following is required:

- Non-bleed TXV on the indoor coil or install liquid line solenoid valve near indoor unit with flow arrow pointing toward indoor unit.
- Insulated liquid line in unconditioned space only. Insulated suction line full length.
- Suction line should slope toward the indoor unit
- Follow the proper line sizing, maximum linear and equivalent lengths, charging requirements, and oil level adjustments spelled out in this manual.
- Verify at least 5°F [2.8°C] liquid sub-cooling at the indoor unit prior to expansion device.

# 4.0 INSTALLATION



## 4.5 Line Set Installation (cont.)

### 4.5.2.2 Outdoor Unit Below Indoor Unit

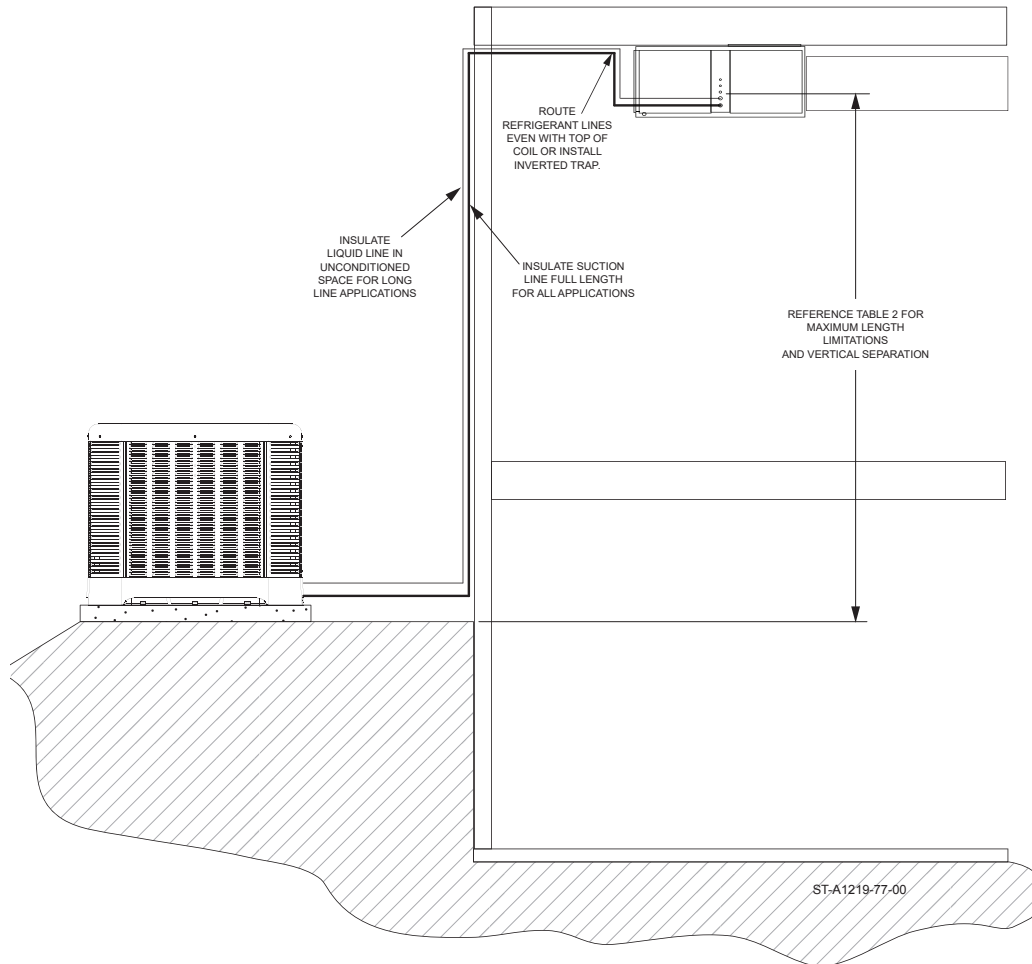

For applications that are considered to have a long line set with the outdoor unit below the indoor unit the following is required:

- Non-bleed TXV or at the indoor coil or install liquid line solenoid valve near indoor unit with flow arrow pointing toward indoor unit.
- Refrigerant lines should be routed even with the top of the indoor coil or an inverted trap is to be applied (refer to above illustration).
- Insulated liquid line in unconditioned space only. Insulated suction line full length.

- Follow the proper line sizing, maximum linear and equivalent lengths, charging requirements, and oil level adjustments spelled out in this manual.
- Verify at least 5°F [2.8°C] liquid sub-cooling at the indoor unit prior to expansion device.
- Vertical separations greater than 25' [7.62 m] can expect a lower sub-cooling level.

# 4.0 INSTALLATION



## 4.5 Line Set Installation (cont.)

### 4.5.2.3 Outdoor Unit Above Indoor Unit

OUTDOOR UNIT ABOVE INDOOR SECTION LINE SET

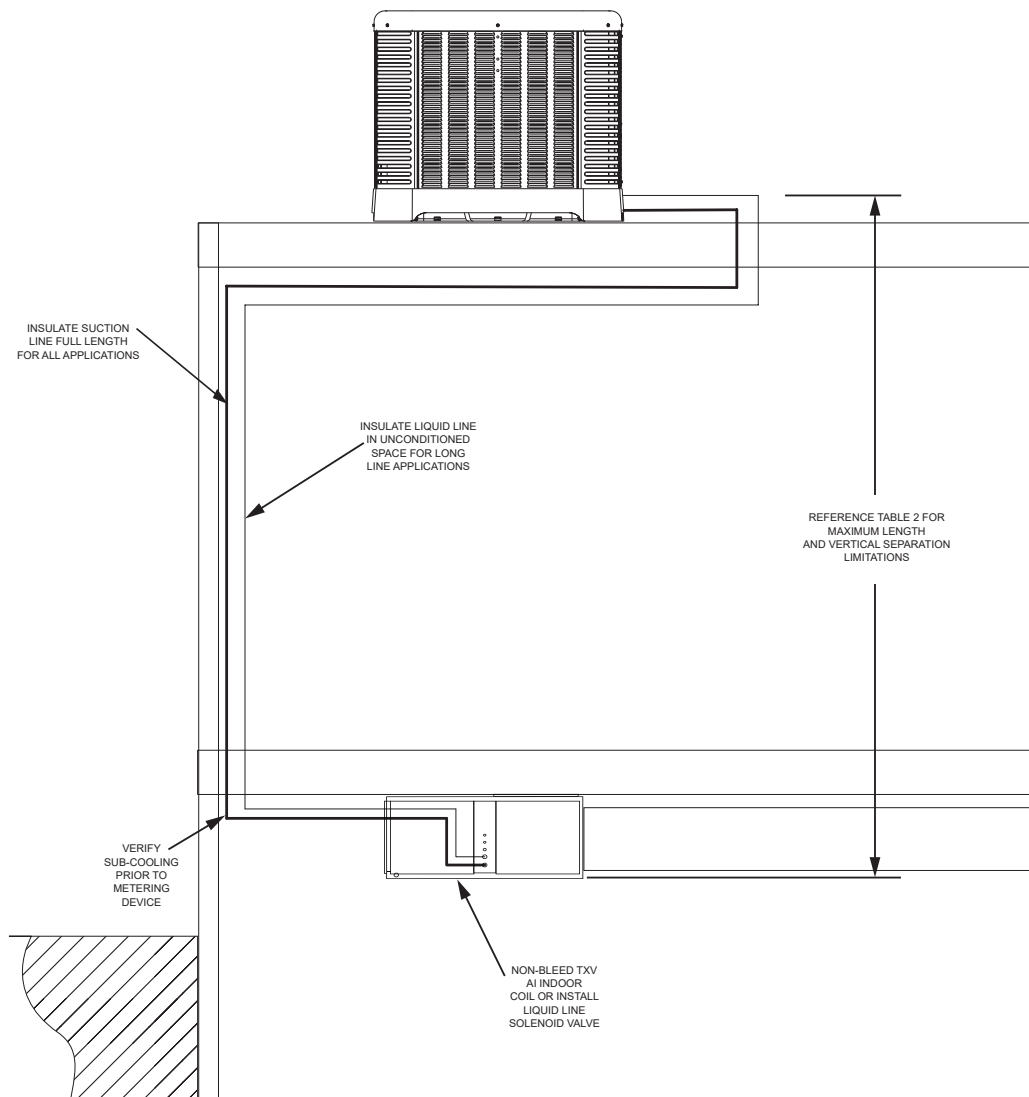

For applications that are considered to have a long line set with the outdoor unit above the indoor unit the following is required:

- Non-bleed TXV on the indoor coil or install liquid line solenoid valve near indoor unit with flow arrow pointing toward indoor unit.
- Insulated liquid line in unconditioned space only. Insulated suction line full length.
- Follow the proper line sizing, maximum linear

and equivalent lengths, charging requirements, and oil level adjustments spelled out in this manual.

# 4.0 INSTALLATION



## 4.5 Line Set Installation (cont.)

### 4.5.3 Tubing Connections

Indoor coils have only a holding charge of dry nitrogen. Keep all tube ends sealed until connections are to be made.

- Use type “L” copper refrigeration tubing. Braze the connections with the following alloys:
  - Copper to copper, 5% silver minimum
  - Copper to steel or brass, 15% silver minimum

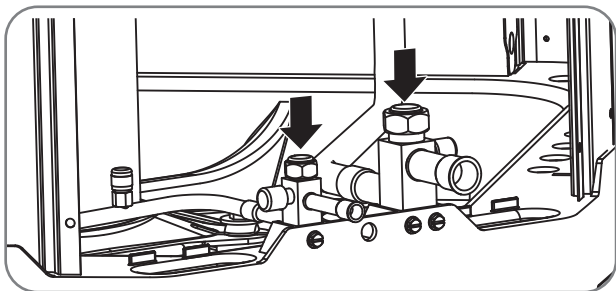

- Be certain both refrigerant shutoff valves at the outdoor unit are closed.

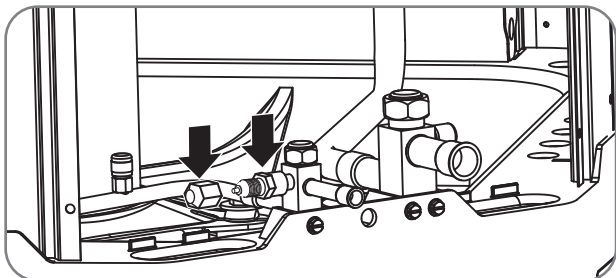

- Remove the caps and Schrader cores from the pressure ports to protect seals from heat damage. Both the Schrader valves and the service valves have seals that may be damaged by excessive heat.

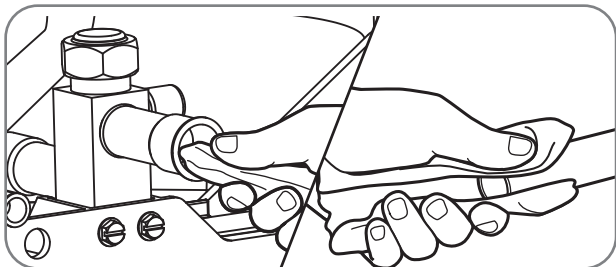

- Clean the inside of the fittings and outside of the tubing with a clean, dry cloth before soldering. Clean out debris, chips, dirt, etc., that enters tubing or service valve connections.

**NOTE:** Service valves and pressure port locations may be slightly different than shown in illustrations.

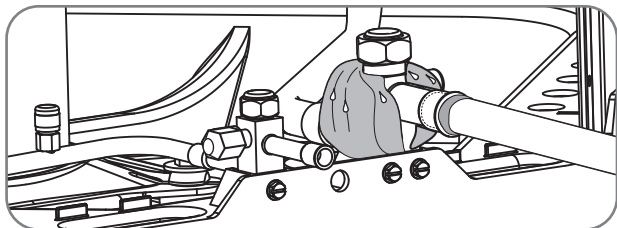

- Wrap valves with a wet rag or thermal barrier compound before applying heat.

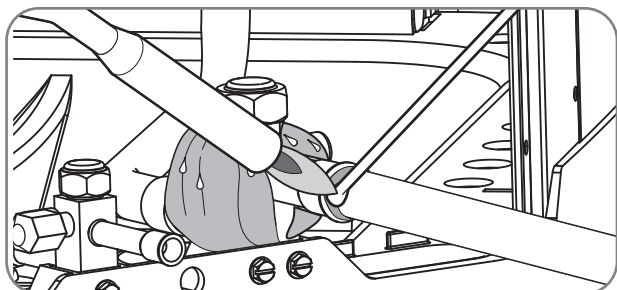

- Braze the tubing between the outdoor unit and indoor coil. Flow dry nitrogen into a pressure port and through the tubing while brazing, but do not allow pressure inside tubing which can result in leaks. Once the system is full of nitrogen, the nitrogen regulator should be turned off to avoid pressuring the system.

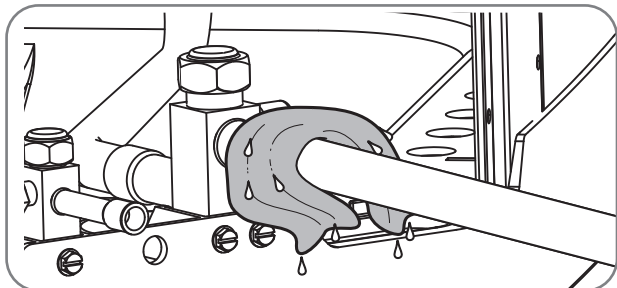

- After brazing, use an appropriate heatsink material to cool the joint.
- Reinstall the Schrader cores into both pressure ports.

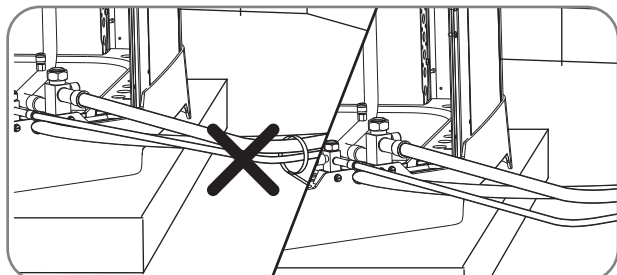

- Do not allow the bare suction line and liquid line to be in contact with each other. This causes an undesirable heat transfer resulting in capacity loss and increased power consumption.



# 4.0 INSTALLATION

## 4.6 Initial Leak Testing

Indoor coils have only a holding charge of dry nitrogen. Keep all tube ends sealed until connections are to be made.

**⚠WARNING:** Do not use oxygen to purge lines or pressurize system for leak test. Oxygen reacts violently with oil, which can cause an explosion resulting in severe personal injury or death.

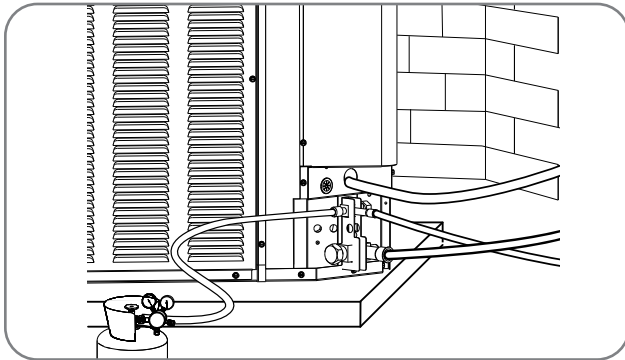

- Pressurize line set and coil through service fittings with dry nitrogen to a maximum of 150 PSIG [1034 kPa]. Close nitrogen tank valve, let system sit for at least 15 minutes, and check to see if the pressure has dropped. If the pressure has dropped, check for leaks at the line set braze joints with soap bubbles and repair leak as necessary. Repeat pressure test. If line set and coil hold pressure, proceed with line set and coil evacuation (see Sections 4.7 and 4.8 for evacuation and final leak testing).

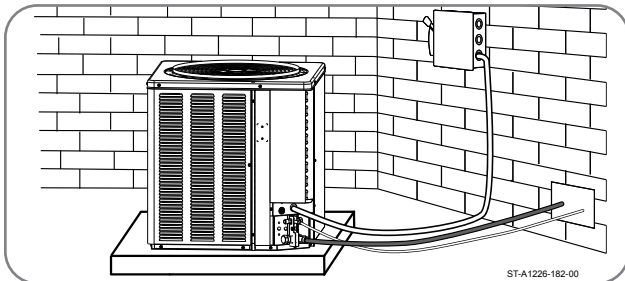

- The suction line must be insulated for its entire length to prevent dripping (sweating) and prevent performance losses. Closed-cell foam insulation such as Armaflex and Rubatex® are satisfactory insulations for this purpose. Use 1/2" [12.7 mm] minimum insulation thickness. Additional insulation may be required for long runs. The liquid line must be insulated in any unconditioned space when long line sets are used and anytime the liquid line is run through an attic due to hot temperatures that occur there.

**NOTE:** Units shown in illustrations are generic representations and may differ from the actual unit being installed.

## 4.7 Evacuation

Evacuation is one of the most important parts of the entire installation and service procedure. The life and efficiency of the equipment is dependent upon the thoroughness exercised by the serviceman when evacuating air and moisture from the system.

Air or nitrogen in the system increases condensing temperature and pressure, resulting in increased power consumption, erratic operation, and reduced capacity.

Moisture chemically reacts with the refrigerant and oil to form corrosive acid which attacks the compressor motor windings and internal parts and which can result in compressor failure.

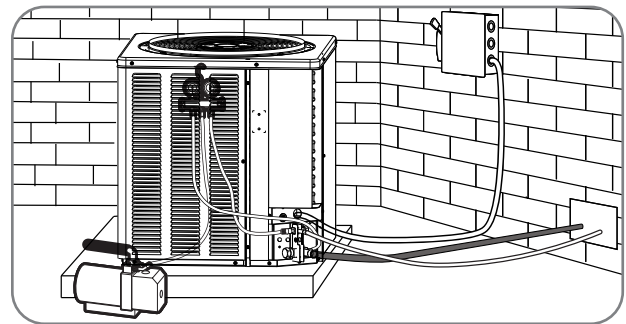

**IMPORTANT:** The outdoor units are shipped with a nitrogen holding charge and must be evacuated along with the line set and indoor coil.

After the system has been leak-checked and proven leak free, open both outdoor unit service valves and connect the vacuum pump to the hose from the middle port of the manifold gauge set. Connect the high and low side hoses to the service ports on both service valves. Open both valves on the gauge set completely before starting the vacuum pump. Evacuate system to 500 microns and hold 500 microns or less for at least 15 minutes. Use the largest size connections available since restrictive service connections may lead to false readings because of pressure drop through the fittings.

# 4.0 INSTALLATION



## 4.8 Control Wiring

**⚠ WARNING:** Turn off electric power at the fuse box or service panel before making any electrical connections. Also, the ground connection must be completed before making line voltage connections. Failure to do so can result in electrical shock, severe personal injury, or death.

Running low-voltage wires in conduit with line voltage power wires is not recommended. Low-voltage wiring is to be connected to the pigtails hanging down from the bottom of the control box.

A thermostat and a 24-volt, 75 VA (10-15 ton) or 100 VA (20 ton) minimum transformer are required for the control circuit of the system. The appropriately sized transformer is supplied in the outdoor unit from the factory. See the wiring diagram for reference. Use "Wire Size" guide

below to size the 24-volt control wiring.

Do not use phone cord to connect indoor and outdoor units and thermostat. This could damage the controls and may not be adequately sized for the control's electrical load.

### FIELD WIRE SIZE FOR 24-VOLT THERMOSTAT CIRCUITS:

Runs up to 100 ft [30.5 m]: 18 AWG  
Runs over 100 ft [30.5 m]: 16 AWG

NOTICE: Do not use control wiring smaller than No. 18 AWG between thermostat and outdoor unit.



## 4.9 Typical Field Wiring Connections

The following diagram shows the typical wiring connections for a two-stage condensing unit and an air-handler with electric heat.

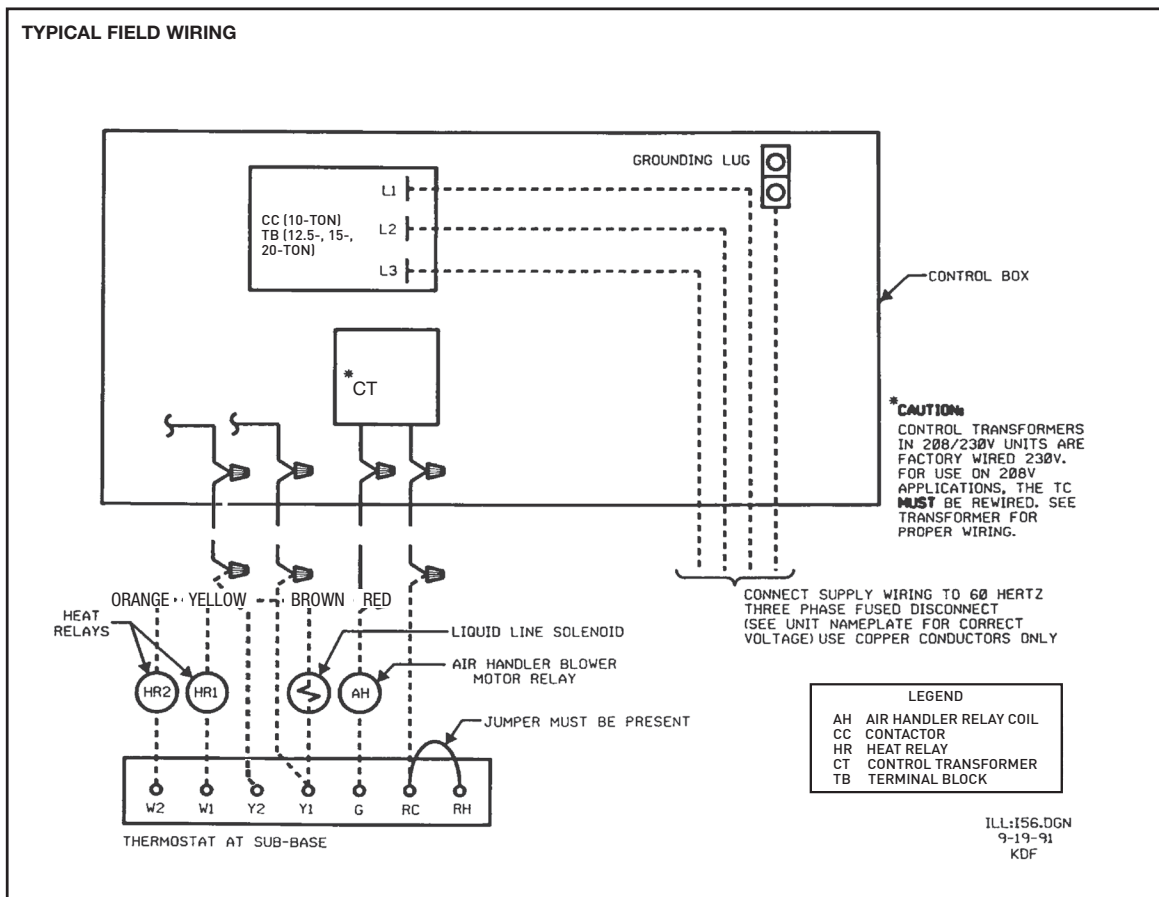

# 4.0 INSTALLATION



## 4.10 Configuring Control Transformer for 208V Applications

The control transformer supplied with 208/230V models is factory wired for 230V applications and must be reconfigured for 208V applications upon installation by disconnecting the Orange transformer primary lead from the compressor contactor L1 terminal and connecting the Red transformer primary lead to the compressor L1 terminal. The Orange and Red transformer primary lead terminals are insulated to prevent the disconnected lead from shorting to ground, but the terminal on the disconnected Orange transformer lead should still be secured with a wire tie so it is isolated from ground as to assure it cannot come in contact with a grounded surface and short the transformer out.

### 4.11 Power Wiring

It is important that proper electrical power from a commercial utility is available at the outdoor unit contactor. Voltage ranges for operation are shown below.

#### VOLTAGE RANGES (60 HZ)

Nameplate Voltage	Operating Voltage Range at Maximum Load Design Conditions for Compressors
208/230 (1 Phase)	187 - 253
208/230 (3 Phase)	187 - 253
460	414 - 506
575	517 - 633

Install a branch circuit disconnect within sight of the unit and of adequate size to handle the minimum circuit capacity (see Section 3.2).

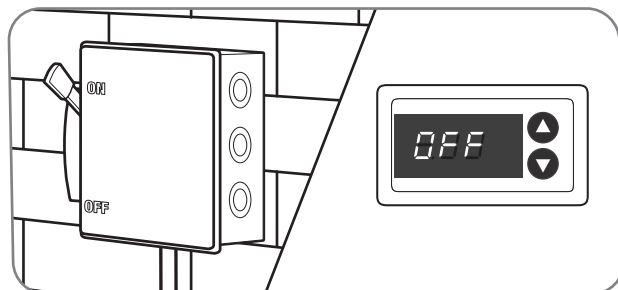

Power wiring must be run in a rain-tight conduit. Conduit must be run through the connector panel below the access cover (see illustration in sections 3.2 and 3.3) and attached to the bottom of the control box.

Connect power wiring to line-voltage lugs located

in the unit electrical box. (See illustration on page 11 of this manual. The lugs will be on the compressor contactor for the 10 Ton model and on a terminal block for the 12.5 -20 Ton models.)

Check all electrical connections, including factory wiring within the unit and make sure all connections are tight.

DO NOT connect aluminum field wire to the contactor terminals.

### 4.12 Grounding

**⚠WARNING:** The unit must be permanently grounded. Failure to do so can cause electrical shock resulting in severe personal injury or death.

A grounding lug is provided for a ground wire inside the control box on the left side. (See bottom illustration on page 11 of this manual.)

# 5.0 SYSTEM START-UP & REFRIGERANT CHARGING

## 5.1 Start-Up Overview

Once the system hardware and wiring have been properly installed and the system has been properly evacuated, the next step is to weigh in the preliminary refrigerant charge and conduct a final leak check before applying electrical power and starting the system.

When the system is first started, indoor blower motor rotation, compressor rotation, and indoor air-flow, must be verified prior to the refrigerant charge being finalized using pressures and the charging chart attached to the inside of the control box cover.

To achieve optimum system reliability and comfort, it is important to follow the procedures in the following sections to assure the indoor air-flow and the refrigerant charge are correct.

**CAUTION:** R-410A pressures are approximately 60% higher (1.6 times) than R-22 pressures. Use appropriate care when using this refrigerant. Failure to exercise care may result in equipment damage or personal injury.

**IMPORTANT:** Both the outdoor and indoor units are shipped with a nitrogen holding charge. Starting the system prior to evacuating the system and adding refrigerant or while system is in a vacuum will result in damage to the compressor.

**IMPORTANT:** After the preliminary refrigerant charge has been weighed in, it is recommended that the electrical power be applied to the outdoor unit for 12 hours before the compressor is started to allow the crankcase heater to drive any liquid refrigerant from the compressor shell.

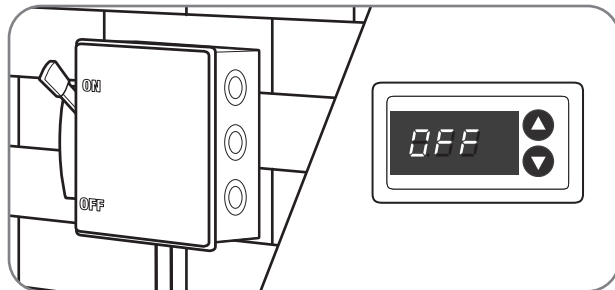

## 5.2 Preliminary Charging by Weight and Final Leak Check

After the system has been properly evacuated, close the valves on the manifold gauge set and disconnect the vacuum pump. Connect the center hose from the manifold gauge set to the R-410a refrigerant tank. Open the valve on the refrigerant tank and then loosen the hose at the gauge set slightly to purge the air from the hose, then retighten the hose at the gauge set. Invert the refrigerant tank and place it on an accurate weight scale (+/-1 oz [28.3g]). Inverting the refrigerant tank will direct only liquid refrigerant to the unit.

**IMPORTANT:** R-410A is a blended refrigerant of R-32 and R-125. These two refrigerants have different saturation curves and therefore change state at different pressures and temperatures. If charge is added to the system in the vapor stage, it is possible to have a disproportionate amount of R-32 and R-125 which will cause unstable and inefficient operation. Therefore, it is critical to add R-410A in the liquid form only.

Refer to the basic system charge from the unit data plate (or table below) and add to that the required weight of refrigerant for the line set length. Calculate the total preliminary refrigerant charge using the following tables and formulas.

REQUIRED OZS. R-410A PER FT. OF

Tube Size O.D., In. [mm]	Liquid oz/ft [g/m]	Vapor oz/ft [g/m]
1/2 [12.7]	1.06 [100.5]	0.04 [3.7]
5/8 [15.9]	1.65 [153.5]	0.07 [6.5]
3/4 [19.1]	2.46 [228.8]	0.10 [9.3]
7/8 [22.2]	3.28 [305.1]	0.13 [12.1]
1 1/8 [28.6]		0.22 [20.5]
1 3/8 [34.9]		0.34 [31.6]
1 5/8 [41.3]		0.48 [44.7]
2 1/8 [54.0]		0.84 [78.1]

Quantities based on 110°F liquid and 45°F vapor.

BASIC SYSTEM CHARGE\*

MODEL	FACTORY CHARGE OZ (g)	SYSTEM CHARGE OZ (g)
(-)ACL2120	0 (0)	422 (11,964)
(-)ACL2150	0 (0)	414 (11,737)
(-)ACL2180	0 (0)	582 (16,500)
(-)ACL2240	0 (0)	650 (18,428)

\*System with 0 Feet of Tubing

# 5.0 SYSTEM START-UP & REFRIGERANT CHARGING

Charge Adjustment = Total Linear Line Length x (oz/ft or g/m for liquid line + oz/ft or g/m for suction line)

Preliminary Refrigerant Charge = Basic System Charge + Charge Adjustment

Example: A 10 ton system requires 75 ft. of line set with a 5/8" liquid line and 1-3/8" suction line.

Charge Adjustment = 75 ft. x (1.65 oz/ft + 0.34 oz/ft) = 75 ft. x 1.99 oz/ft. = 149 oz (rounded to nearest oz)

Basic Refrigerant Charge = 437 oz

Preliminary Refrigerant Charge = 437 oz + 149 oz = 586 oz (36.63 lb)

Open the high side valve of the manifold gauge set and allow as much refrigerant to flow into the high side of the system as possible up to the preliminary refrigerant charge. Then open the low side valve of the manifold gauge set and finish weighing in the preliminary refrigerant charge. If the system will not take the entire preliminary charge, the remaining amount of charge can be added once the outdoor unit is started up.

Close both valves on the manifold gauge set and conduct a final leak check on all of the braze joints between the indoor and outdoor units using a halogen leak detector. If a leak is detected, the refrigerant must be recovered before repairing the leak. The Clean Air Act prohibits releasing refrigerant into the atmosphere.

## 5.3 Pre-Start Check

- |                          |     |                          |    |     |  |
|--------------------------|-----|--------------------------|----|-----|--|
| <input type="checkbox"/> | YES | <input type="checkbox"/> | NO | 1.  | Is condensing unit properly located and level?   |
| <input type="checkbox"/> | YES | <input type="checkbox"/> | NO | 2.  | Is air free to travel to and from condensing unit?                                     |
| <input type="checkbox"/> | YES | <input type="checkbox"/> | NO | 3.  | Is the wiring correct and according to the unit wiring diagram?                        |
| <input type="checkbox"/> | YES | <input type="checkbox"/> | NO | 4.  | Are wiring connections tight? (including those in unit and compressor electrical box.) |
| <input type="checkbox"/> | YES | <input type="checkbox"/> | NO | 5.  | Is the unit properly grounded?   |
| <input type="checkbox"/> | YES | <input type="checkbox"/> | NO | 6.  | Is circulating air blower correctly wired?   |
| <input type="checkbox"/> | YES | <input type="checkbox"/> | NO | 7.  | Is condensing unit properly fused?   |
| <input type="checkbox"/> | YES | <input type="checkbox"/> | NO | 8.  | Is the thermostat level, correctly wired and in a good location?                       |
| <input type="checkbox"/> | YES | <input type="checkbox"/> | NO | 9.  | Is the ductwork correctly sized, run, taped and insulated?                             |
| <input type="checkbox"/> | YES | <input type="checkbox"/> | NO | 10. | Is refrigerant tubing neatly run and vapor line thoroughly insulated?                  |
| <input type="checkbox"/> | YES | <input type="checkbox"/> | NO | 11. | Is condensate drain line properly sized, run, tapped and pitched?                      |
| <input type="checkbox"/> | YES | <input type="checkbox"/> | NO | 12. | Are refrigerant connections tight and leak tested?                                     |
| <input type="checkbox"/> | YES | <input type="checkbox"/> | NO | 13. | Is filter clean and in place?  |
| <input type="checkbox"/> | YES | <input type="checkbox"/> | NO | 14. | Does the condenser fan turn free without rubbing?                                      |
| <input type="checkbox"/> | YES | <input type="checkbox"/> | NO | 15. | Is the fan tight in the fan shaft?   |
| <input type="checkbox"/> | YES | <input type="checkbox"/> | NO | 16. | Are all covers and access panels in place to prevent air loss?                         |

# 5.0 SYSTEM START-UP & REFRIGERANT CHARGING

## 5.4 Initial System Start-Up: Verifying Correct Indoor Blower Motor and Compressor Rotation.

After the refrigerant charge is weighed in, it is recommended that electrical power be applied to both the indoor and outdoor units for a minimum of 12 hours with the thermostat turned to the OFF position to give the crankcase heater time to drive liquid refrigerant from the compressor shell. After 12 hours, the thermostat may be adjusted to call for the cooling mode. It is very important at this point to verify that the indoor blower motor rotation (3-phase air-handlers) and compressor rotation are both correct to prevent damage to the compressor.

- If the 3-phase indoor blower is turning backwards (blower turning, but no air-flow), shut the electrical power off to the indoor and outdoor units and reverse two incoming line voltage leads to the air-handler. Restore electrical power to the indoor and outdoor units and verify the indoor blower motor rotation is correct and air is flowing through the ductwork.
- Check to make sure the liquid pressure increases and the suction pressure decreases when the compressor first starts, indicating the compressor rotation is correct. If there is no pressure differential and the compressor is making a loud rattling sound, shut the electrical power off to the outdoor unit and reverse two of the incoming power leads at the outdoor unit contactor. Restore electrical power to the outdoor unit and confirm the liquid pressure increases the suction pressure decreases, and the compressor is operating at a normal sound level.

Note: The outdoor fan motor is a single phase motor and will therefore always have the correct rotation regardless of how the electrical power is connected to the contactor.

## 5.5 Verifying Indoor Air-Flow

Before final refrigerant charge adjustment, the indoor air-flow must be verified and adjusted if necessary. Adjust the thermostat set point so the indoor air-handler or furnace operates in the cooling air-flow mode. Some air-handlers and furnaces deliver a different air-flow level for continuous fan operation, so it is important to verify the indoor air-flow while the thermostat is set to operate in the cooling mode. Determine the rated indoor air-flow by referring to the AHRI

Directory, manufacturer's specifications, or engineer's specification for the matched system. If this information is not available, 350 - 400 CFM per ton is a good rule of thumb. Refer to the air-handler or gas furnace installation and operation manual for air-flow tables and for adjusting the cooling mode indoor air-flow. External static pressure will need to be measured and used for this adjustment. For furnace/coil combinations, the coil pressure drop is considered part of the external static pressure to the furnace. An air velocity meter or air-flow hood can also give an accurate reading for indoor air-flow.

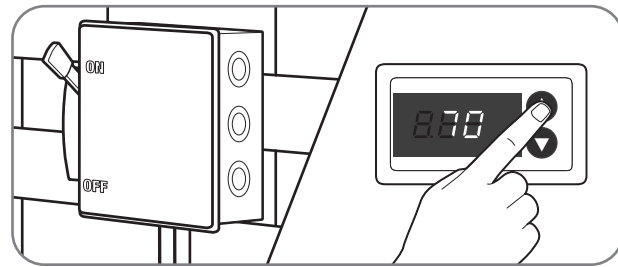

## 5.6 Charging

1) Once the indoor air-flow is verified, operate the system for a minimum of 15 minutes in the cooling mode prior to checking pressures and the outdoor ambient temperature.

**IMPORTANT:** Indoor conditions must be within 2°F [1.1°C] of comfort conditions per the building manager's preference for final refrigerant charging. If the indoor temperature is above or below this range, continue running the system in the cooling mode or run the furnace or electric heat to bring the temperature to within this range.

2) Locate the system charging chart on the inside of the control box cover or in Section 5.7 of this manual.

3) Note the Outdoor Dry Bulb Temperature, Suction (Vapor) Pressure, and Liquid Pressure.

4) Find the intersection of the Suction (Vapor) Pressure on the appropriate Outdoor Ambient Temperature line and note the Liquid Pressure on the chart. If the outdoor ambient is between two of the outdoor ambient lines on the chart, estimate the liquid pressure as required.

5) If the measured liquid pressure is below the liquid pressure indicated on the charging chart, add refrigerant to the system. If the measured liquid pressure is above the liquid pressure indicated on the charging chart, remove refrigerant from the

# 5.0 SYSTEM START-UP & REFRIGERANT CHARGING

system. Allow the system to stabilize for 5 minutes before rechecking the pressures against the chart.

6) Repeat steps 4 and 5 as required.

7) Once the pressures are correct, allow the system to operate for a minimum of 15 minutes and recheck the pressures against the charging chart, adjust charge as needed, and repeat until the pressures are correct after 15 minutes of operating at that charge level.

## Final Charge by Subcooling

**IMPORTANT:** Charging by weight or pressure is not always accurate since the application can affect the optimum refrigerant charge. Charging by weight or pressure is considered a starting point ONLY. Always check the charge by using the Charging Chart and adjust as necessary. CHARGING BY LIQUID SUBCOOLING MUST BE USED FOR FINAL CHARGE ADJUSTMENT.

1. After gross charging, note the designed subcooling value on the Charging Chart located inside the access panel cover.  $SC^\circ$  from Charging Chart =  $_____^\circ F$  [ $_____^\circ C$ ].

**IMPORTANT:** Verify that the outdoor unit is operating in second stage and the indoor air mover is delivering the correct airflow for the system size. Indoor conditions as measured at the indoor coil are required to be between  $70^\circ F$  [ $21.1^\circ C$ ] and  $75^\circ F$  [ $23.9^\circ C$ ] dry bulb for fine-tuned unit charge adjustment. Unit charging is recommended under the following outdoor conditions ONLY: Cooling Mode ONLY:  $55^\circ F$  [ $12.8^\circ C$ ] outdoor dry bulb and above

**NOTICE:** If the indoor temperature is above or below the recommended range, run the system to bring the temperature down or run the electric heat/furnace to bring the temperature up. System subcooling values provided in the Charging Chart for outdoor dry bulbs corresponding to conditions outside of the above range are provided as reference ONLY.

2. Note the measured Liquid Pressure,  $P_{liq}$  =  $_____$  psig, as measured from the liquid (small) service valve. Use the Temperature Pressure Chart below to note the corresponding saturation temperature for R-410A at the measured liquid pressure. Liquid Saturation Temperature,  $SAT^\circ = _____^\circ F$  [ $_____^\circ C$ ].

3. Note the liquid line temperature,  $Liq^\circ = _____^\circ F$  [ $_____^\circ C$ ], as measured from a temperature probe located within 6" [15.2 cm] outside of the unit on the copper liquid line (small line). It is recommended to use a calibrated clamp-on temperature probe or an insulated surface thermocouple.

4. Subtract the liquid line temperature from the saturation temperature to calculate subcooling.  $SAT^\circ _____^\circ F$  [ $_____^\circ C$ ] -  $Liq^\circ _____^\circ F$  [ $_____^\circ C$ ] =  $SC^\circ _____^\circ F$  [ $_____^\circ C$ ]

5. Adjust charge to obtain the specified subcooling value. If the measured subcool is below the listed requirement for the given outdoor and indoor conditions, add charge. If the measured subcool is above the listed requirement for the given outdoor and indoor conditions, remove charge.

TEMPERATURE PRESSURE CHART							
SATURATION TEMP (Deg. F) [Deg. C]	R-410A PSIG	SATURATION TEMP (Deg. F) [Deg. C]	R-410A PSIG	SATURATION TEMP (Deg. F) [Deg. C]	R-410A PSIG	SATURATION TEMP (Deg. F) [Deg. C]	R-410A PSIG
-150 [-101]	-	-30 [-34]	17.9	35 [2]	107.5	100 [38]	317.4
-140 [-96]	-	-25 [-32]	22.0	40 [4]	118.5	105 [41]	340.6
-130 [-90]	-	-20 [-29]	26.4	45 [7]	130.2	110 [43]	365.1
-120 [-84]	-	-15 [-26]	31.3	50 [10]	142.7	115 [46]	390.9
-110 [-79]	-	-10 [-23]	36.5	55 [13]	156.0	120 [49]	418.0
-100 [-73]	-	-5 [-21]	42.2	60 [16]	170.1	125 [52]	446.5
-90 [-68]	-	0 [-18]	48.4	65 [18]	185.1	130 [54]	476.5
-80 [-62]	-	5 [-15]	55.1	70 [21]	201.0	135 [57]	508.0
-70 [-57]	-	10 [-12]	62.4	75 [24]	217.8	140 [60]	541.2
-60 [-51]	0.4	15 [-9]	70.2	80 [27]	235.6	145 [63]	576.0
-50 [-46]	5.1	20 [-7]	78.5	85 [29]	254.5	150 [66]	612.8
-40 [-40]	10.9	25 [-4]	87.5	90 [32]	274.3		
-35 [-37]	14.2	30 [-1]	97.2	95 [35]	295.3		

# 5.0 SYSTEM START-UP & REFRIGERANT CHARGING

## 5.7 CHARGING CHARTS

Split System Air Conditioner 10 Tons  
 System Charge Chart - Refrigerant 410A  
 Basic System Charge With 0 Feet Of Tubing = 422 oz.  
 Add Additional Amount As Shown In Table Below

### COOLING

Design Subcooling @ 95°F Ambient = 15.5°F (At Service Valve)

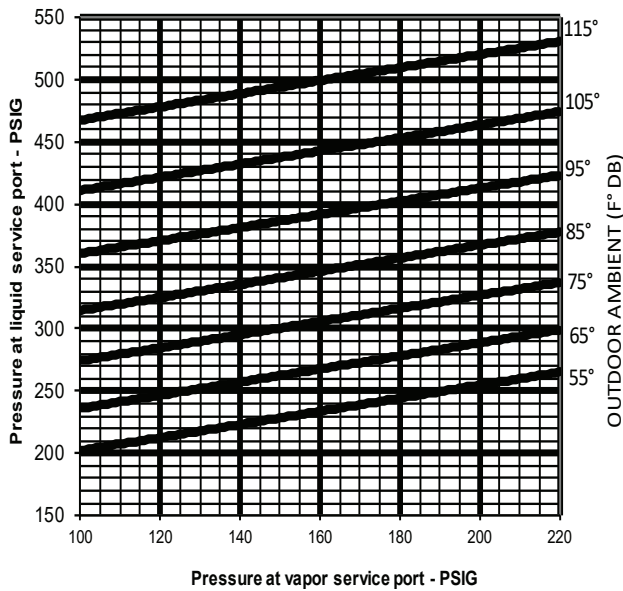

### Cooling Instructions

Caution: Return Air Temperature Must Be Between 70° & 75° Before Final Refrigerant Check.

#### INSTRUCTIONS:

1. Connect Pressure Gauges To Vapor And Liquid Ports At Outdoor Unit.
2. Measure Air Temperature To The Unit (Outdoor Dry Bulb Ambient).
3. Place An "X" On The Chart Where The Vapor And Liquid Pressure Cross.
4. If "X" Is Below Outdoor Temperature Line, Add Charge And Repeat 3.
5. If "X" Is Above Indoor Temperature Line, Recover Charge And Repeat 3.
6. Pressures Are Ref. Only -Final Charge Verification To Be Based On "Design Subcooling" Note At The Top Of The Cooling Chart.

Required Ounces R-410A Charge Per Foot of Tubing		
Tube Size O.D. in. [mm]	Liquid Tube oz [g]	Vapor Tube oz [g]
1/2 [12.7]	1.06 [30.0]	.04 [1.13]
5/8 [15.88]	1.65 [46.7]	.07 [1.98]
3/4 [19.05]	2.46 [69.7]	.10 [2.83]
7/8 [22.23]	3.28 [92.9]	.13 [3.68]
1-1/8 [28.58]		.22 [6.23]
1-3/8 [34.93]		.34 [9.63]
1-5/8 [41.28]		.48 [13.60]
2-1/8 [53.98]		.84 [23.81]

Quantities based on 110°F liquid and 45°F vapor.

92-108042-03 



# 5.0 SYSTEM START-UP & REFRIGERANT CHARGING

## 5.7 CHARGING CHARTS

Split System Air Conditioner 12.5 Tons  
 System Charge Chart - Refrigerant 410A  
 Basic System Charge With 0 Feet Of Tubing = 414 oz.  
 Add Additional Amount As Shown In Table Below

### COOLING

Design Subcooling @ 95°F Ambient = 15.2°F (At Service Valve)

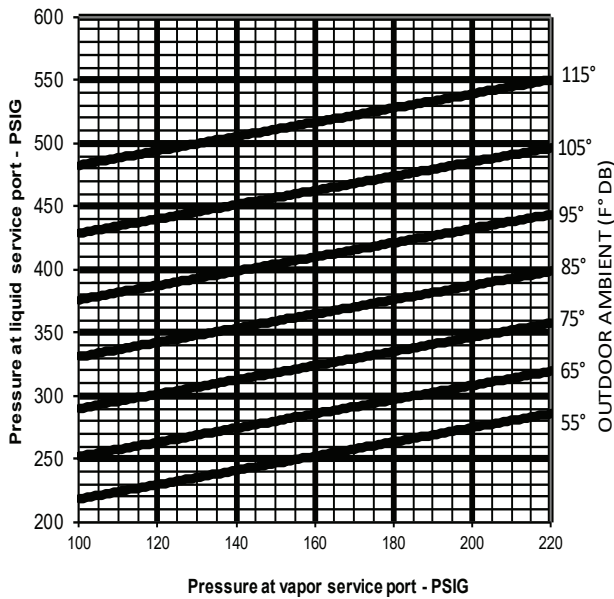

### Cooling Instructions

Caution: Return Air Temperature Must Be Between 70° & 75° Before Final Refrigerant Check.

#### INSTRUCTIONS:

1. Connect Pressure Gauges To Vapor And Liquid Ports At Outdoor Unit.
2. Measure Air Temperature To The Unit (Outdoor Dry Bulb Ambient).
3. Place An "X" On The Chart Where The Vapor And Liquid Pressure Cross.
4. If "X" Is Below Outdoor Temperature Line, Add Charge And Repeat 3.
5. If "X" Is Above Indoor Temperature Line, Recover Charge And Repeat 3.
6. Pressures Are Ref. Only -Final Charge Verification To Be Based On "Design Subcooling" Note At The Top Of The Cooling Chart.

Required Ounces R-410A Charge Per Foot of Tubing

Tube Size O.D. in. [mm]	Liquid Tube oz [g]	Vapor Tube oz [g]
1/2 [12.7]	1.06 [30.0]	.04 [1.13]
5/8 [15.88]	1.65 [46.7]	.07 [1.98]
3/4 [19.05]	2.46 [69.7]	.10 [2.83]
7/8 [22.23]	3.28 [92.9]	.13 [3.68]
1-1/8 [28.58]		.22 [6.23]
1-3/8 [34.93]		.34 [9.63]
1-5/8 [41.28]		.48 [13.60]
2-1/8 [53.98]		.84 [23.81]

Quantities based on 110°F liquid and 45°F vapor.

92-108042-04

# 5.0 SYSTEM START-UP & REFRIGERANT CHARGING

## 5.7 CHARGING CHARTS

Split System Air Conditioner 15 Tons  
 System Charge Chart - Refrigerant 410A  
 Basic System Charge With 0 Feet Of Tubing = 582 oz.  
 Add Additional Amount As Shown In Table Below

### COOLING

Design Subcooling @ 95°F Ambient = 14.4°F (At Service Valve)

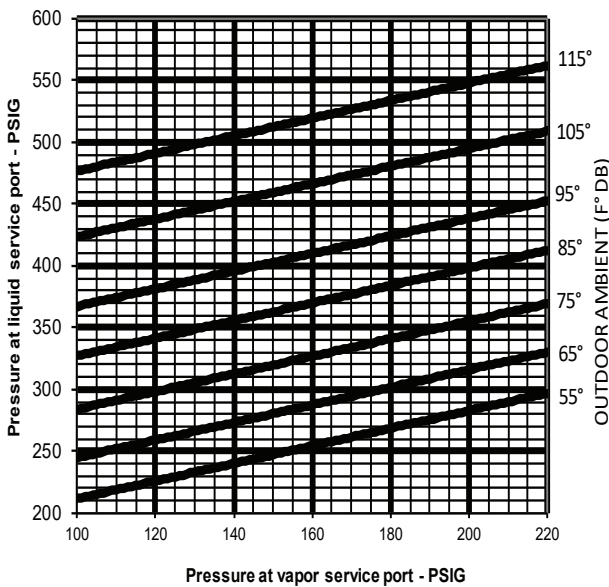

### Cooling Instructions

Caution: Return Air Temperature Must Be Between 70° & 75° Before Final Refrigerant Check.

#### INSTRUCTIONS:

1. Connect Pressure Gauges To Vapor And Liquid Ports At Outdoor Unit.
2. Measure Air Temperature To The Unit (Outdoor Dry Bulb Ambient).
3. Place An "X" On The Chart Where The Vapor And Liquid Pressure Cross.
4. If "X" Is Below Outdoor Temperature Line, Add Charge And Repeat 3.
5. If "X" Is Above Indoor Temperature Line, Recover Charge And Repeat 3.
6. Pressures Are Ref. Only -Final Charge Verification To Be Based On "Design Subcooling" Note At The Top Of The Cooling Chart.

Required Ounces R-410A Charge Per Foot of Tubing		
Tube Size O.D. in. [mm]	Liquid Tube oz [g]	Vapor Tube oz [g]
1/2 [12.7]	1.06 [30.0]	.04 [1.13]
5/8 [15.88]	1.65 [46.7]	.07 [1.98]
3/4 [19.05]	2.46 [69.7]	.10 [2.83]
7/8 [22.23]	3.28 [92.9]	.13 [3.68]
1-1/8 [28.58]		.22 [6.23]
1-3/8 [34.93]		.34 [9.63]
1-5/8 [41.28]		.48 [13.60]
2-1/8 [53.98]		.84 [23.81]

Quantities based on 110°F liquid and 45°F vapor.

92-108042-05

# 5.0 SYSTEM START-UP & REFRIGERANT CHARGING

## 5.7 CHARGING CHARTS

Split System Air Conditioner 20 Tons  
 System Charge Chart - Refrigerant 410A  
 Basic System Charge With 0 Feet Of Tubing =650 oz  
 Add Additional Amount As Shown In Table Below

### COOLING

Design Subcooling @ 95°F Ambient = 19°F (At Service Valve)

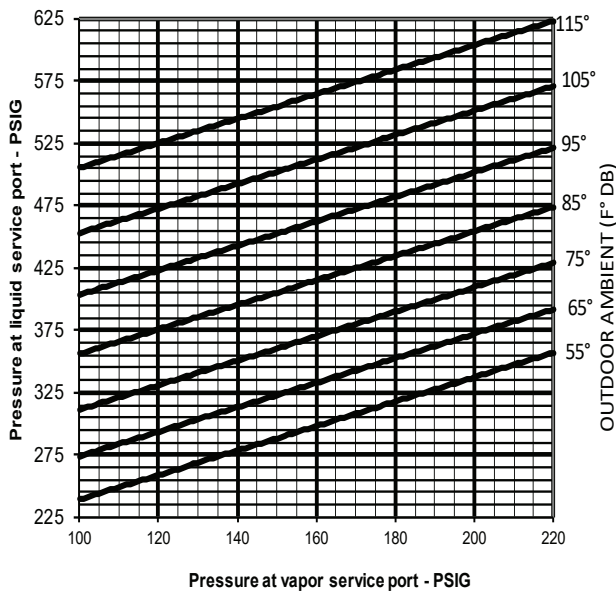

### Cooling Instructions

Caution: Return Air Temperature Must Be Between 70° & 75° Before Final Refrigerant Check.

#### INSTRUCTIONS:

1. Connect Pressure Gauges To Vapor And Liquid Ports At Outdoor Unit.
2. Measure Air Temperature To The Unit (Outdoor Dry Bulb Ambient).
3. Place An "X" On The Chart Where The Vapor And Liquid Pressure Cross.
4. If "X" Is Below Outdoor Temperature Line, Add Charge And Repeat 3.
5. If "X" Is Above Indoor Temperature Line, Recover Charge And Repeat 3.
6. Pressures Are Ref. Only -Final Charge Verification To Be Based On "Design Subcooling" Note At The Top Of The Cooling Chart.

Required Ounces R-410A Charge Per Foot of Tubing

Tube Size O.D. in. [mm]	Liquid Tube oz [g]	Vapor Tube oz [g]
1/2 [12.7]	1.06 [30.0]	.04 [1.13]
5/8 [15.88]	1.65 [46.7]	.07 [1.98]
3/4 [19.05]	2.46 [69.7]	.10 [2.83]
7/8 [22.23]	3.28 [92.9]	.13 [3.68]
1-1/8 [28.58]		.22 [6.23]
1-3/8 [34.93]		.34 [9.63]
1-5/8 [41.28]		.48 [13.60]
2-1/8 [53.98]		.84 [23.81]

Quantities based on 110°F liquid and 45°F vapor.

92-108042-01 

# 5.0 SYSTEM START-UP & REFRIGERANT CHARGING

## 5.8 Completing Installation

- Disconnect the hoses from the pressure ports. Replace the pressure port caps and tighten adequately to seal caps. **Do not overtighten.**
- Replace the service valve top caps finger-tight and then tighten with a wrench to adequately seal caps. **Do not overtighten.**
- Replace control box cover and service panel and install screws to secure panels.
- Restore power to unit at disconnect if required.
- Configure thermostat per the thermostat installation instructions and set to desired mode and temperature.

## 6.0 SEQUENCE OF OPERATION

### 6.1 Sequence Of Operation (-)ACL2120 (Two-Stage Compressor)

1. When the room thermostat is set on “Cool”, “Fan Auto”, and the temperature is higher than the thermostat setting, the thermostat “Y1” circuit closes and energizes the first speed of the compressor contactor (CC). Power to the crankcase heater (CCH) will be de-energized by the auxiliary contacts (AUX).
2. Simultaneously, the “G” circuit provides power to the indoor blower motor circuit and starts indoor air circulation through the evaporator coil.
3. When the discharge pressure increases to 450 psig, the contacts on the low ambient control (LAC) (if installed) will allow supply power to start the outdoor fan motors (OFM) which begins to pull air through the condenser coils. The system is now in the first-stage cooling, operating at near 60 percent of full load capacity.
4. If the temperature at the thermostat continues to increase, the thermostat “Y2” circuit closes and energizes both speeds of the compressor which is now full load capacity.
5. The system will continue cooling at maximum capacity, as long as the room thermostat is demanding full load and all safety device contacts are closed. The low ambient control (LAC) (if installed) will open and close, allowing the outdoor fans to maintain discharge pressure between 250 and 450 psig.
6. As the temperature at the thermostat drops enough to satisfy “Y2”, the circuit will open and de-energize the second compressor speed and continues operating on the first speed of the compressor.
7. When continued cooling satisfies the “Y1” circuit, it will open and de-energize the compressor contactor (CC), stopping compressor operation and closing the auxiliary contacts (AUX), which energizes the crankcase heater (CCH).
8. The thermostat “G” circuit will stop blower

operation.

### 6.2 Sequence Of Operation (-)ACL2150, (-)ACL2180, (-)ACL2240 (Tandem Compressor)

1. When the room thermostat is set on “Cool”, “Fan Auto”, and the temperature is higher than the thermostat setting, the thermostat “Y1” circuit closes and energizes the number one compressor contactor (CC1) through the closed cooling relay (RL) contacts. Power to the crankcase heater (CCH1) will be de-energized by the auxiliary contacts (AUX1).
2. Simultaneously, the “G” circuit provides power to the indoor blower motor circuit and starts indoor air circulation through the evaporator coil.
3. When the discharge pressure increases to 450 psig, the contacts on the low ambient control (LAC) (if installed) will allow supply power to start the outdoor fan motors (OFM) which begin to pull air through the condenser coils. The system is now in first stage cooling, operating at near fifty percent of full load capacity.
4. If the temperature at the thermostat continues to increase, the thermostat “Y2” circuit closes and after a full 30 second delay, power passes through the time delay control (TDC) and energizes the number two compressor contactor (CC2) through the second set of closed cooling relay (RL) contacts. Power to the crankcase heater (CCH2) will be de-energized by the auxiliary contacts (AUX2).
5. The system will continue cooling at maximum capacity, as long as the room thermostat is demanding full load and all safety device contacts are closed. The low ambient control (LAC) (if installed) will open and close, allowing the outdoor fans to maintain discharge pressure between 250 and 450 psig.
6. As the temperature at the thermostat drops enough to satisfy “Y2”, the circuit will open and de-energize the compressor contactor (CC2),

# 6.0 SEQUENCE OF OPERATION

stopping compressor operation and closing the auxiliary contacts (AUX2), which energizes the crankcase heater (CCH2).

- When continued cooling satisfies the “Y1” circuit, it will open and de-energize the compressor contactor (CC1), stopping compressor operation

and closing the auxiliary contacts (AUX1), which energizes the crankcase heater (CCH1).

- The thermostat “G” circuit will stop blower operation.

# 7.0 COMPONENTS & CONTROLS

## 7.1 Compressor

A single 2-stage 3-phase scroll compressor is used in 10 ton models. Tandem 3-phase scroll compressors are used in 12.5-20 ton models.

## 7.2 Fan Motor

All models utilize ECM motors.

## 7.3 Outdoor Fan

The 10- and 12.5-ton models utilize a three-blade 'swept-style' fans while the 15- and 20-ton models use 'paddle-style' four-blade fans.

## 7.4 Compressor Contactor

All models utilize either one (10 ton) or two (12.5-20 ton) 3-pole contactors to power the compressors and fan motors. Field power is connected directly to the terminal lugs on the line side of the contactor on the (-)ACL2120.

## 7.5 Compressor Crankcase Heater (CCH)

Each compressor is equipped with a belly-band style crankcase heater that is energized anytime electrical power is supplied to the unit. 12.5-20 ton models with tandem compressors have a crankcase heater on each compressor. Crankcase heater wattages for each model are shown in the following table.

MODEL	CRANKCASE HEATER(S)
(-)ACL2120	(1) 70W
(-)ACL2150 & (-)ACL2180	(1) 70W and (1) 40W
(-)ACL2240	(2) 70W

All heaters are located on the lower half of the compressor shell. Its purpose is to drive refrigerant from the compressor shell during long off cycles, thus preventing damage to the compressor during start-up.

At initial start-up or after extended shutdown periods, make sure the heater is energized for at least 12 hours before the compressor is started. (Disconnect switch is on and wall thermostat is off.)

## 7.6 Compressor Time Delay (12.5 – 20 Ton Models Only)

A compressor time delay is factory installed on 12.5 – 20 ton models that have tandem compressors to provide a delay between stages to minimize inrush current in case both stages are energized simultaneously.

## 7.7 High- and Low-Pressure Controls (HPC and LPC)

High and low pressure controls are standard on all models.

The high-pressure control (HPC) is an automatic-reset which opens near 610 PSIG [4206 kPa] and closes near 420 PSIG [2896 kPa].

The low-pressure control (LPC) is an automatic-reset which opens near 50 PSIG [345 kPa] and closes near 95 PSIG [655 kPa].

**⚠ CAUTION:** The compressor has an internal overload protector. Under some conditions, it can take up to 2 hours for this overload to reset. Make sure overload has had time to reset before condemning the compressor.

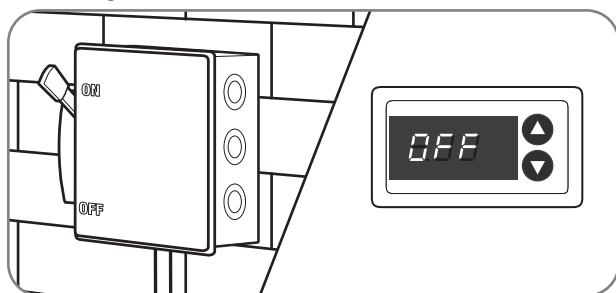

# 7.0 COMPONENTS & CONTROLS

## 7.8 Line Voltage Terminal Block for Field Connections

12.5 – 20 ton models have a terminal block inside the control box for connecting line voltage supply wiring. Line voltage supply wiring is connected to the compressor contactor lugs on 10 ton models.

## 7.9 Transformer

A 75VA (10-12.5 ton) or 100VA (15-20 ton) transformer is provided inside the unit control box for supplying 24V AC for both the outdoor and indoor unit control system. 208V applications require the transformer to be reconfigured upon installation (See Section 4.11).

# 8.0 ACCESSORIES

**⚠WARNING:** Turn off electric power at the fuse box or service panel before making any electrical connections while installing accessories. Failure to do so can result in electrical shock, severe personal injury, or death.

## 8.1 Liquid Line Solenoid Valve (24V)

**Recommended** for all split system applications without a non-bleed TXV on the indoor coil, to prevent refrigerant migration during off cycles. Solenoid valve is to be located in liquid line near air handler.

Part No. **RXAV-CD120** (10-12.5 ton)  
**RXAV-CD180** (15-20 ton)

## 8.2 Sight Glass

**SIGHT GLASS** — Allows viewing of the refrigerant. Bubbles may indicate a shortage of refrigerant or a restriction in the liquid line. The color indicator shows relative moisture saturation of the refrigerant. Its inclusion in the refrigerant piping is recommended. A minimum of 12 hours after installation is required before attempting to determine if a moisture condition within the system exists.

Part No. **RXAG-A048** (10-12.5 ton)  
**RXAG-A020** (15-20 ton)

## 8.3 Low Ambient Control (LAC)

Cycles outdoor fans to maintain adequate discharge pressure. Opens at 250 psig and closes at 450 psig.

Part No. **RXAD-08** (10-20 ton)

# 9.0 DIAGNOSTICS & TROUBLESHOOTING

## 9.1 Cooling Mechanical Checks Flowchart

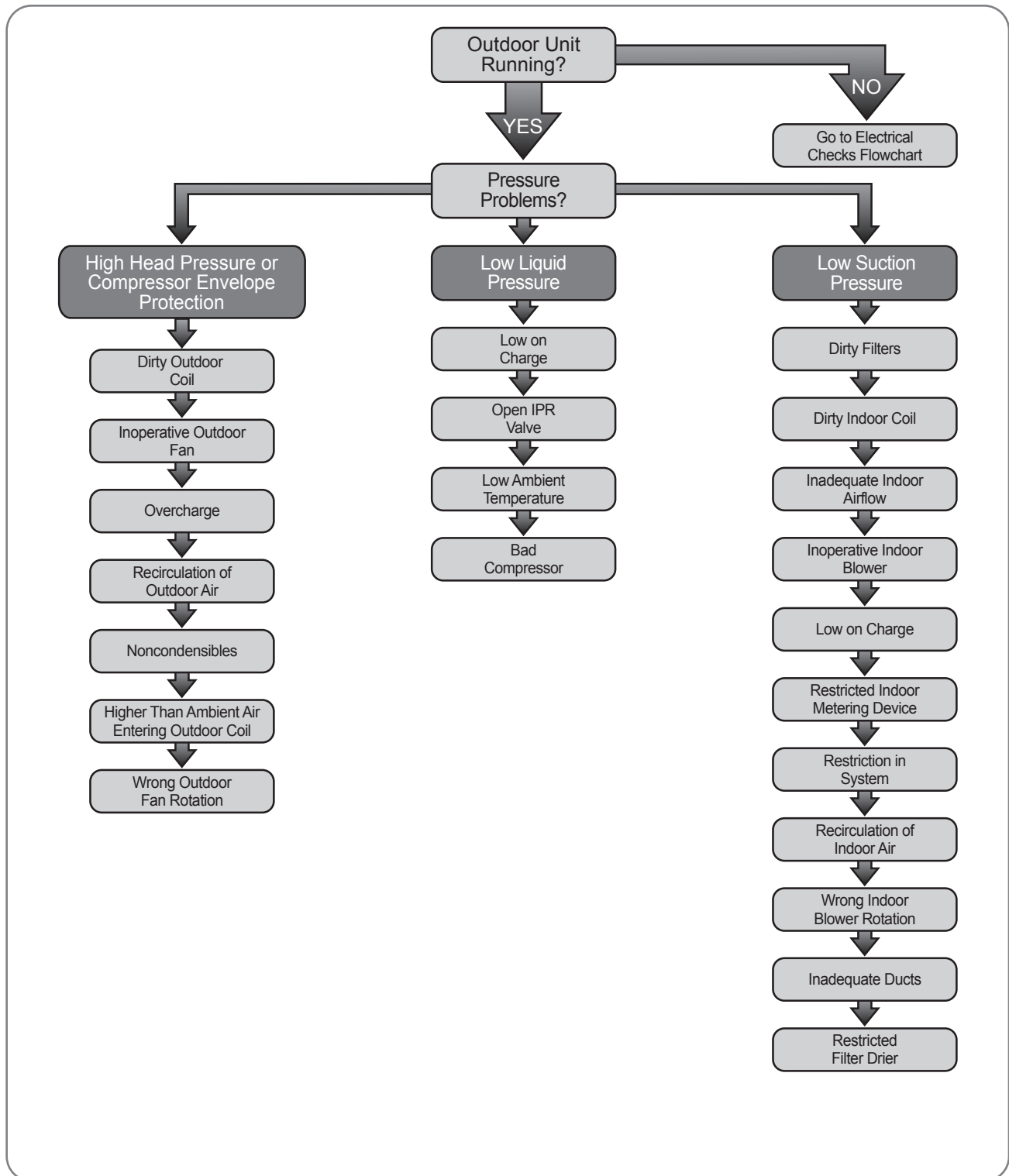

# 9.0 DIAGNOSTICS & TROUBLESHOOTING

## 9.2 General Troubleshooting Guide

**⚠ WARNING:** Disconnect all power to unit before servicing. Contactor may break only one side. Failure to shut off power can cause electrical shock resulting in personal injury or death.

Diagnostics

SYMPTOM	POSSIBLE CAUSE	REMEDY
Unit will not run	<ul style="list-style-type: none"> <li>Power off or loose electrical connection</li> <li>Thermostat out of calibration – set too low or high</li> <li>Blown fuses/tripped breaker</li> <li>Transformer defective</li> <li>High-pressure control open</li> <li>Low pressure control open</li> <li>Miswiring of thermostat</li> </ul>	<ul style="list-style-type: none"> <li>Check for correct voltage at line voltage connections in condensing unit.</li> <li>Adjust thermostat.</li> <li>Replace fuses/reset breaker.</li> <li>Check wiring. Replace transformer.</li> <li>See high head pressure remedy.</li> <li>See low suction pressure remedy.</li> <li>Check thermostat wiring.</li> </ul>
Outdoor fan runs, compressor doesn't	<ul style="list-style-type: none"> <li>Loose connection</li> <li>Compressor stuck, grounded or open motor winding, open internal overload.</li> </ul>	<ul style="list-style-type: none"> <li>Check for correct voltage at compressor. Check and tighten all connections.</li> <li>Wait at least 3 hours for overload to reset. If still open, replace the compressor.</li> </ul>
Insufficient cooling	<ul style="list-style-type: none"> <li>Improperly sized unit</li> <li>Improper indoor airflow</li> <li>Incorrect refrigerant charge</li> <li>Air, noncondensibles, or moisture in system</li> <li>Restricted refrigerant circuit</li> </ul>	<ul style="list-style-type: none"> <li>Recalculate building load.</li> <li>Check. Should be approximately 350-400 CFM [165-189 L/s] per ton.</li> <li>Charge per procedure attached to unit service panel.</li> <li>Recover refrigerant. Evacuate and recharge.</li> <li>Locate restriction and clear. Add or replace filter drier.</li> </ul>
Compressor short cycles	<ul style="list-style-type: none"> <li>Incorrect voltage</li> <li>Defective overload protector</li> <li>Refrigerant undercharge or overcharge (HPC or LPC cycling)</li> </ul>	<ul style="list-style-type: none"> <li>At compressor terminals, voltage must be <math>\pm 10\%</math> of nameplate marking when unit is operating.</li> <li>Replace compressor. Check for correct voltage.</li> <li>Adjust charge per charging chart.</li> </ul>
Registers sweat	<ul style="list-style-type: none"> <li>Low indoor airflow</li> </ul>	<ul style="list-style-type: none"> <li>Increase speed of blower or reduce restriction. Replace air filter.</li> </ul>
High head, low suction pressures	<ul style="list-style-type: none"> <li>Restriction in liquid line, expansion device, or filter drier</li> <li>Bad TXV</li> </ul>	<ul style="list-style-type: none"> <li>Remove or replace defective component.</li> <li>Replace TXV.</li> </ul>
High head, high or normal suction pressure	<ul style="list-style-type: none"> <li>Dirty outdoor coil</li> <li>Refrigerant overcharge</li> <li>Outdoor fan not running</li> <li>Air or noncondensibles in system</li> </ul>	<ul style="list-style-type: none"> <li>Clean coil.</li> <li>Correct system charge.</li> <li>Repair or replace.</li> <li>Recover refrigerant. Evacuate and recharge.</li> </ul>
Low head, high vapor pressures	<ul style="list-style-type: none"> <li>Bad TXV</li> <li>Bad compressor</li> </ul>	<ul style="list-style-type: none"> <li>Replace TXV.</li> <li>Replace compressor.</li> </ul>
Low suction pressure, iced indoor coil	<ul style="list-style-type: none"> <li>Low indoor airflow</li> <li>Operating below 65°F [18°C] outdoors</li> <li>Moisture in system</li> <li>Low refrigerant charge</li> </ul>	<ul style="list-style-type: none"> <li>Increase speed of blower or reduce restriction. Replace air filter.</li> <li>Add Low Ambient Kit.</li> <li>Recover refrigerant. Evacuate and recharge. Add filter drier.</li> <li>Check refrigerant charge and check for leaks.</li> </ul>
High suction pressure	<ul style="list-style-type: none"> <li>Excessive load</li> <li>Defective compressor</li> </ul>	<ul style="list-style-type: none"> <li>Recheck load calculation.</li> <li>Replace.</li> </ul>
Fluctuating head and suction pressures	<ul style="list-style-type: none"> <li>TXV hunting</li> <li>Air or noncondensibles in system</li> </ul>	<ul style="list-style-type: none"> <li>Check TXV bulb clamp. Check air distribution on coil. Replace TXV.</li> <li>Recover refrigerant. Evacuate and recharge.</li> </ul>
Gurgle or pulsing noise at expansion device or liquid line	<ul style="list-style-type: none"> <li>Air or noncondensibles in system</li> <li>Undercharged system</li> </ul>	<ul style="list-style-type: none"> <li>Recover refrigerant. Evacuate and recharge.</li> <li>Adjust charge per charging chart.</li> </ul>



# 9.0 DIAGNOSTICS & TROUBLESHOOTING

## 9.3 Service Analyzer Charts

COMPRESSOR OVERHEATING			
SYMPTOM	POSSIBLE CAUSE	CHECK/REMEDY	
High superheat (greater than 15°F [8.3°C] at coil)	Low charge	Check system charge.	
	Faulty metering device	Restricted cap tube, TXV	
		Power element superheat out of adjustment internally	
		Foreign matter stopping flow	
	High internal load	Hot air (attic) entering return	
		Heat source on; miswired or faulty control	
	Restriction in liquid line	Drier plugged.	
		Line kinked.	
	Low head pressure	Low charge	
		Operating in low ambient temperatures	
Suction or liquid line subjected to high heat source	Hot attic		
	Hot water line		
Low line voltage	Loose wire connections	Check wiring.	
	Power company problem, transformer	Report Problem.	
	Undersized wire feeding unit	Correct and complete diagnosis.	
High line voltage	Power company problem	Report problem.	
High head pressure	Overcharge	Check system charge.	
	Dirty outdoor coil	Clean coil.	
	Faulty or wrong size outdoor fan motor	Replace fan motor.	
	Faulty fan blade or wrong rotation	Replace fan blade.	
		Replace with correct rotation motor.	
	Recirculation of air	Correct installation.	
	Additional heat source	Check for dryer vent near unit.	
		Check for recirculation from other equipment.	
Noncondensibles	Recover refrigerant. Evacuate and recharge system.		
Equipment not matched	Correct mismatch.		
Short cycling of compressor	Cycling or faulty pressure control	Check pressure and address cause of high or low pressure. Replace pressure control if faulty.	
	Loose wiring	Check unit wiring.	
	Thermostat	Located in supply air stream	
		Differential setting too close	
		Customer misuse	
	Indoor coil TXV / Distributor Restriction	Internal foreign matter	
		Power element failure	
		TXV too small	
		Equilizer tube plugged	
Indoor coil distributor tube restricted	Restricted with foreign matter		
	Kinked		
	Inside diameter reduced from previous compressor failure		

# 9.0 DIAGNOSTICS & TROUBLESHOOTING

## 9.3 Service Analyzer Charts (cont.)

COMPRESSOR OVERHEATING (cont.)		
SYMPTOM	POSSIBLE CAUSE	CHECK OR REMEDIES
Short cycling of compressor (cont.)	Low charge	Check system charge.
	Low evaporator airflow	Dirty coil
		Dirty filter
		Duct too small or restricted
	Faulty run capacitor	Replace.
Faulty internal overload	Replace compressor.	
Faulty Compressor Valves or scrolls	Fast equalization/Low pressure difference	Replace compressor and examine system to locate reason.

ELECTRICAL		
SYMPTOM	POSSIBLE CAUSE	CHECK OR REMEDIES
Voltage present on load side of compressor contactor and compressor won't run	Internal overload	Allow time to reset.
	Compressor windings	Check for correct ohms.
Voltage present on line side of compressor contactor only	Thermostat	Check for control voltage to contactor coil.
	Compressor control circuit	High-pressure switch
		Low-pressure switch
		Ambient thermostat
		Solid-state protection control or internal thermal sensors
Compressor timed off/on control or interlock		
No voltage on line side of compressor contactor	Blown fuses or tripped circuit breaker	Check for short in wiring or unit.
	Improper wiring	Recheck wiring diagram.
Improper voltage	High voltage	Wrong unit
		Power supply problem
	Low voltage	Wrong unit
		Power supply problem
		Wiring undersized
	Loose connections	
Single Phasing (3 phase)	Check incoming power and fusing.	

FLOODED STARTS		
SYMPTOM	POSSIBLE CAUSE	CHECK OR REMEDIES
Liquid in the compressor shell	Faulty or missing crankcase heater	Replace crankcase heater.
Too much liquid in system	Incorrect piping	Check piping guidelines.
	Overcharge	Check and adjust charge.

# 9.0 DIAGNOSTICS & TROUBLESHOOTING

## 9.3 Service Analyzer Charts (cont.)

CONTAMINATION		
SYMPTOM	POSSIBLE CAUSE	REMEDY
Moisture	Poor evacuation on installation or during service	In each case, the cure is the same. Recover refrigerant. Add filter drier, evacuate, and recharge.
High head pressure	Noncondensibles air	
Unusual head and suction readings	Wrong refrigerant or mixed refrigerants	
Foreign matter – copper filings	Copper tubing cuttings	
Copper oxide	Dirty copper piping or nitrogen not used when brazing	
Welding scale	Nitrogen not used during brazing	
Soldering flux	Adding flux before seating copper partway	
Excess soft solder	Wrong solder material	
LOSS OF LUBRICATION		
SYMPTOM	POSSIBLE CAUSE	REMEDY
Compressor failures	Vapor line tubing too large	Reduce pipe size to improve oil return.
Low suction pressure	Low charge	Check system charge.
	Refrigerant leaks	Repair and recharge.
Cold, noisy compressor – Slugging	Dilution of oil with refrigerant	Observe piping guidelines.
Noisy compressor	Refrigerant migration in off-cycle	Check or add crankcase heater.
Cold, sweating compressor	Flooding	Check system charge.
Low load	Reduced indoor airflow	Dirty filter
		Dirty indoor coil
		Wrong duct size
	Restricted duct	
	Thermostat setting	Advise customer.
Short cycling of compressor	Cycling or faulty high- or low-pressure control	Check pressure and address cause of high or low pressure. Replace pressure control if faulty.
	Loose wiring	Check all control wires.
	Thermostat	In supply air stream, out of calibration
		Customer misuse
SLUGGING		
SYMPTOM	POSSIBLE CAUSE	REMEDY
On start-up	Incorrect piping	Review pipe size guidelines.
TXV hunting when running	Faulty indoor TXV	Replace TXV.

# 9.0 DIAGNOSTICS & TROUBLESHOOTING

## 9.3 Service Analyzer Charts (cont.)

FLOODING		
SYMPTOM	POSSIBLE CAUSE	REMEDY
Poor system control using a TXV	Loose sensing bulb	Secure the bulb and insulate.
	Bulb in wrong location	Relocate bulb.
	Wrong size TXV	Use correct replacement.
	Improper superheat setting (less than 5°F [2.8°C])	Replace TXV.
THERMOSTATIC EXPANSION VALVE (TXV)		
SYMPTOM	POSSIBLE CAUSE	REMEDY
High Superheat, Low Suction Pressure (superheat over 15°F [8.3°C])	Moisture freezing and blocking valve	Recover charge, install filter-drier, evacuate system, recharge.
	Dirt or foreign material blocking valve	Recover charge, install filter-drier, evacuate system, recharge.
	Low refrigerant charge	Correct the charge.
	Vapor bubbles in liquid line	Remove restriction in liquid line. Correct the refrigerant charge.
		Remove noncondensable gases.
		Size liquid line correctly.
	Misapplication of internally equalized valve	Use correct TXV.
	Plugged external equalizer line	Remove external equalizer line restriction.
	Undersized TXV	Replace with correct valve.
	Loss of charge from power head sensing bulb	Replace power head or complete TXV.
Charge migration from sensing bulb to power head (Warm power head with warm, wet cloth. Does valve operate correctly now?)	Ensure TXV is warmer than sensing bulb.	
Valve feeds too much refrigerant, with low superheat and higher than normal suction pressure	Moisture causing valve to stick open.	Recover refrigerant, replace filter-drier, evacuate system, and recharge.
	Dirt or foreign material causing valve to stick open	Recover refrigerant, replace filter drier, evacuate system, and recharge.
	TXV seat leak (a gurgling or hissing sound is heard AT THE TXV during the off cycle, if this is the cause). NOT APPLICABLE TO BLEED PORT VALVES.	Replace the TXV.
	Oversized TXV	Install correct TXV.
	Incorrect sensing bulb location	Install bulb with two mounting straps, in 2:00 or 4:00 position on suction line, with insulation.
	Low superheat adjustment	Replace TXV.
	Incorrectly installed, or restricted external equalizer line	Remove restriction, or relocate external equalizer.

# 9.0 DIAGNOSTICS & TROUBLESHOOTING

## 9.3 Service Analyzer Charts (cont.)

THERMOSTATIC EXPANSION VALVES (cont.)		
SYMPTOM	POSSIBLE CAUSE	REMEDY
Compressor flood back upon start-up	Refrigerant drainage from flooded evaporator	Install trap riser to the top of the evaporator coil.
	Inoperable crankcase heater or crankcase heater needed	Replace or add crankcase heater.
Superheat is low to normal with low suction pressure	Unequal evaporator circuit loading	Ensure airflow is equally distributed through evaporator. Check for blocked distributor tubes.
	Low load or airflow entering evaporator coil	Ensure blower is moving proper air-flow.
		Remove/Correct any airflow restriction.
Superheat and suction pressure fluctuate (valve is hunting)	TXV is oversized	Install correct TXV.
	Sensing bulb is affected by liquid refrigerant or refrigerant oil flowing through suction line	Relocate sensing bulb in another position around the circumference of the suction line.
	Unequal refrigerant flow through evaporator circuits	Ensure sensing bulb is located properly.
		Check for blocked distributor tubes.
Moisture freezing and partially blocking TXV	Recover refrigerant, change filter-drier, evacuate system, and recharge.	
Valve does not regulate at all	External equalizer line not connected or line plugged	Connect equalizer line in proper location, or remove any blockage.
	Sensing bulb lost its operating charge	Replace TXV.
	Valve body damaged during soldering or by improper installation	Replace TXV.

# 9.0 DIAGNOSTICS & TROUBLESHOOTING

## 9.4 Troubleshooting Tips

COOLING MODE TROUBLESHOOTING TIPS					
SYSTEM PROBLEM	INDICATORS				
	DISCHARGE PRESSURE	SUCTION PRESSURE	SUPERHEAT Normal: 5°-15°F [2.8° - 8.3°C]	SUBCOOLING Normal: See Charging Chart	COMPRESSOR AMPS
Overcharge	High	High	Low	High	High
Undercharge	Low	Low	High	Low	Low
Liquid Restriction (Filter Drier)	Low	Low	High	High	Low
Low Indoor Airflow	Low	Low	Low	Low	Low
Dirty Outdoor Coil	High	High	Low	Low	High
Low Outdoor Ambient Temperature	Low	Low	High	High	Low
Inefficient Compressor	Low	High	High	High	Low
Indoor TXV Sensing Bulb Charge Lost	Low	Low	High	High	Low
Poorly Insulated Indoor Sensing Bulb	High	High	Low	Low	High

# 10.0 OUTDOOR UNIT MAINTENANCE



## 10.1 Outdoor Coil Cleaning

The outdoor fan draws air across the coil during operation which results in contaminants collecting on and between the aluminum fins. These contaminants restrict the air-flow through the coil resulting in reduced capacity and efficiency and increases the temperature of the components that can reduce their life. Therefore, it is recommended that the outdoor coil be cleaned at least annually by a qualified service technician using a non-corrosive coil cleaner and low pressure water hose sprayer. Care must be taken not to damage or flatten out the fins by spraying the fins from

an angle. Washing from the top of the coil down from the inside out is the most effective method of cleaning the coil. The exterior louver panels and unit top are easily removable to facilitate the coil cleaning task.

**WARNING: Disconnect electrical power to the unit before removing the top panel or any electrical panel as the fan motor could start at any time and live electrical connections will be exposed.**



## 10.2 Cabinet Cleaning and Care

Annual cleaning of the exterior cabinet is recommended using a mild detergent, water, and cloth/sponge to remove dust, mold, and potentially corrosive contaminants that have collected on the cabinet. Do not apply wax to the cabinet since the painted surface is textured which will result in a white wax build-up.



## 10.3 Motor Lubrication

The bearings in the outdoor motor are pre-lubricated by the motor manufacturer and do not have oiling ports. The motor will run for an indefinite period of time without additional lubrication.



## 10.4 Replacement Parts

Any replacement part used to replace parts originally supplied on equipment must be the same as or an approved alternate to the original part supplied. The manufacturer will not be responsible for replacement parts not designed to physically fit or operate within the design parameters the original parts were selected for.

# 11.0 WIRING DIAGRAMS

## 11.1 (-)ACL2120 WIRING DIAGRAM/SCHEMATIC (10 TON)

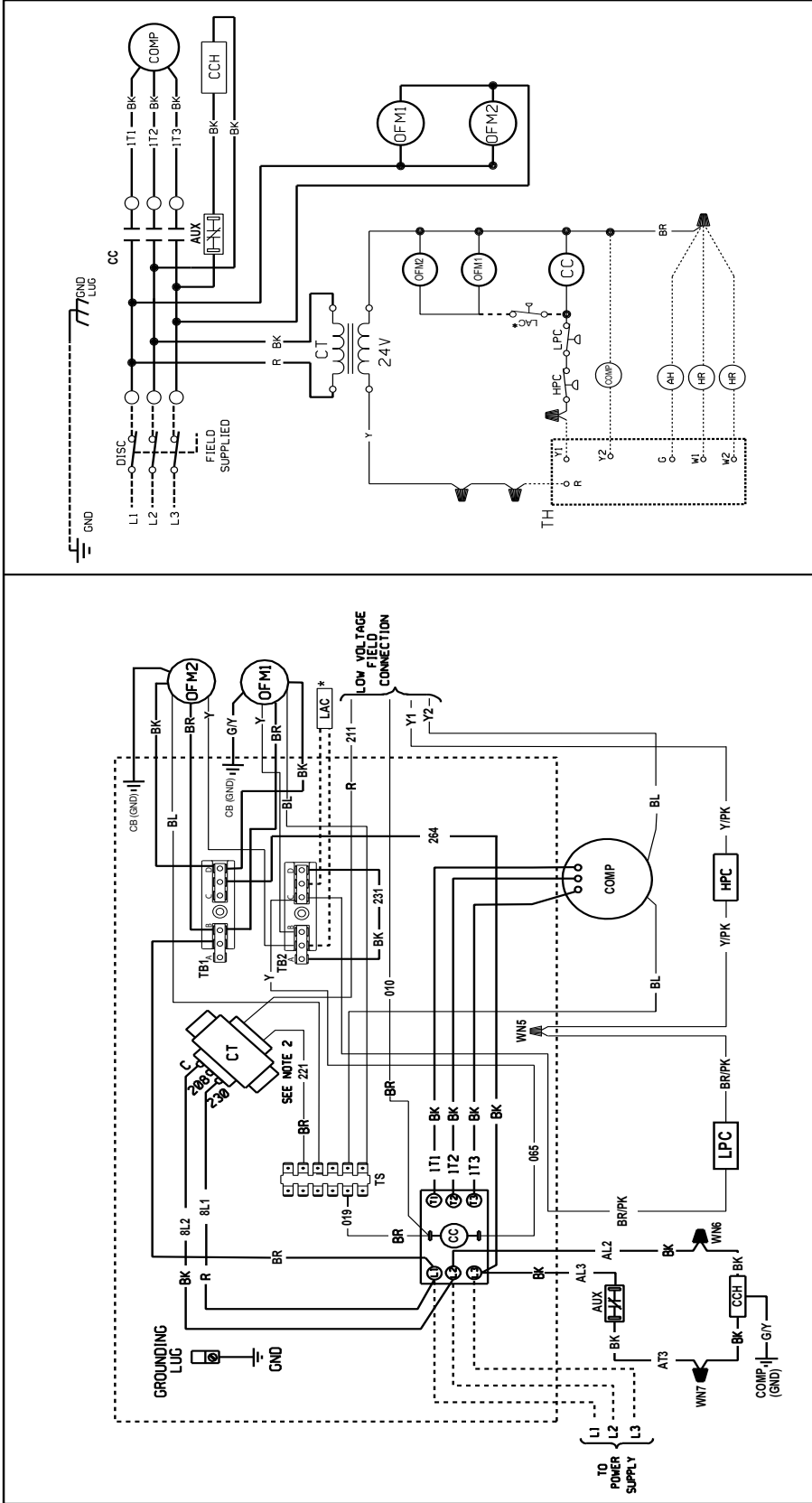

<b>WIRE COLOR CODE</b>	
BK.....BLACK	G.....GREEN
BR.....BROWN	O.....ORANGE
BL.....BLUE	PK.....PINK
	Y.....YELLOW
	PR.....PURPLE
	R.....RED
	W.....WHITE
<b>ELECTRICAL WIRING DIAGRAM/ SCHEMATIC</b>	
<b>CONDENSING UNIT</b>	
10 TON	
208-230, 380, 460	3PH 60Hz &
200-220, 380-415	3PH 50Hz &
- 575	3PH 60Hz
APPROVED:	CHECKED:
NO.:	ORIGINAL RELEASE
MODELED VYM	DATE: 02-10-20
BY:	Y-0699S164
PART NO.:	90-107431-02
	REV: 01

### COMPONENT CODES

- LPC LOW PRESSURE CONTROL
- OFM OUTDOOR FAN MOTOR
- TB TERMINAL BLOCK
- TS THERMOSTAT
- WN WIRE NUT

- AH AIR HANDLER
- AUX AUXILIARY CONTACTOR
- CB CONTROL BOX
- CC COMPRESSOR CONTACTOR
- CCH CRANKCASE HEATER
- COMP COMPRESSOR
- CT CONTROL TRANSFORMER
- GND GROUND
- HPC HIGH PRESSURE CONTROL
- HR HEAT RELAY
- LAC LOW AMBIENT CONTROL

### NOTES

1. ALL THREE-PHASE MOTORS ARE INTERNALLY PROTECTED AGAINST PRIMARY SINGLE-PHASING CONDITIONS.
  2. MAIN UNIT TRANSFORMER PRIMARY SHOWN WIRED FOR 230V OPERATIONS. FOR OTHER VOLTAGE APPLICATIONS WIRE TO COMMON & APPLICABLE VOLTAGE TAP. 208, 460, 575 & ETC.
- \* LAC OPTIONAL

### WIRING INFORMATION

- LINE VOLTAGE
- FACTORY STANDARD
- FACTORY OPTION
- FIELD INSTALLED
- LOW VOLTAGE
- FACTORY STANDARD
- FIELD INSTALLED
- REPLACEMENT WIRE MUST BE THE SAME SIZE AND TYPE OF INSULATION AS ORIGINAL (105C. MIN.)
- CABINET MUST BE PERMANENTLY GROUNDED AND CONFORM TO E.C., N.E.C., C.E.C., LOCAL AND ALL APPLICABLE REGULATIONS, AND LOCAL CODES AS APPLICABLE.



# 11.0 WIRING DIAGRAMS

## 11.2 (-)ACL2150, (-)ACL2180, (-)ACL2240 WIRING DIAGRAM (12.5, 15 & 20 TON)

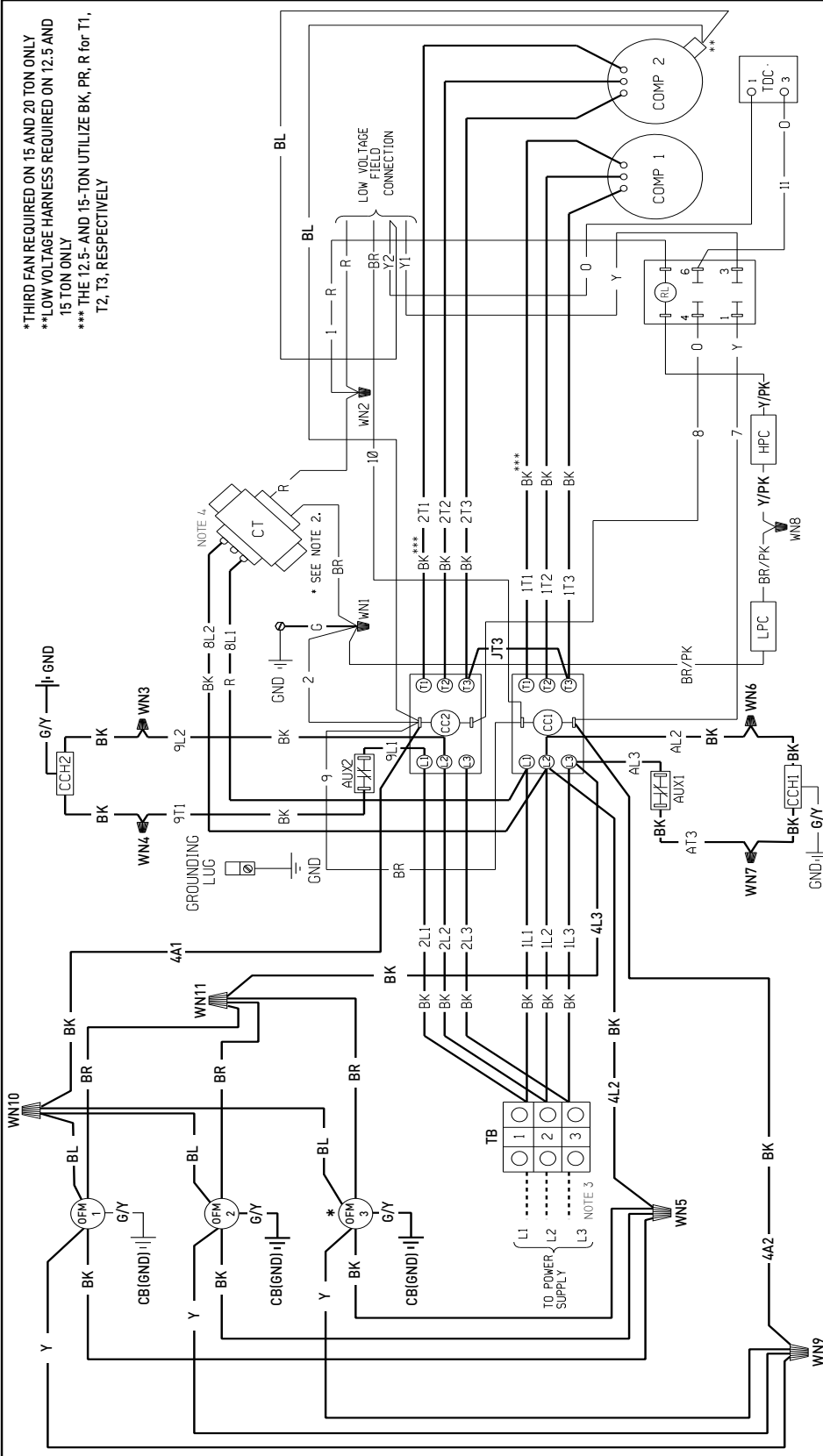

\*THIRD FAN REQUIRED ON 15 AND 20 TON ONLY  
 \*\*LOW VOLTAGE HARNESS REQUIRED ON 12.5 AND 15 TON ONLY  
 \*\*\* THE 12.5- AND 15-TON UTILIZE BK, PR, R FOR T1, T2, T3, RESPECTIVELY

<p><b>WIRING INFORMATION</b></p> <p>LINE VOLTAGE _____          FACTORY STANDARD _____          FACTORY OPTION _____          FE LD INSTALLED _____          LOW VOLTAGE _____          FACTORY STANDARD _____          FE LD INSTALLED _____          REPLACEMENT WIRE _____          MUST BE THE SAME SIZE AND TYPE _____          OF INSULATION AS ORIGINAL (105C, MIN.) _____</p> <p>WARNING          -CABINET MUST BE PERMANENTLY GROUNDED          AND CONFORM TO I.E.C., N.E.C., C.E.C., LOCAL          AND ALL APPLICABLE REGULATIONS, AND LOCAL          CODES AS APPLICABLE.</p>	<p><b>NOTES</b></p> <ol style="list-style-type: none"> <li>1. ALL THREE-PHASE MOTORS ARE INTERNALLY PROTECTED AGAINST PRIMARY SINGLE-PHASING CONDITIONS.</li> <li>2. TRANSFORMER FACTORY WIRED AS SHOWN BELOW. CHANGE PRIMARY VOLTAGE CONNECTION FOR ALTERNATE VOLTAGES, IF REQUIRED.</li> </ol> <table border="1"> <thead> <tr> <th>VOLTAGES-HZ</th> <th>TRANSFORMER</th> </tr> </thead> <tbody> <tr> <td>220-220 - 50 HZ</td> <td>220 OR 240</td> </tr> <tr> <td>220-220 - 60 HZ</td> <td>220 OR 240</td> </tr> <tr> <td>380V - 60 HZ</td> <td>380</td> </tr> <tr> <td>380V-415 - 60 HZ</td> <td>380</td> </tr> <tr> <td>460V - 60 HZ</td> <td>460</td> </tr> <tr> <td>575 - 60 HZ</td> <td>575</td> </tr> </tbody> </table> <ol style="list-style-type: none"> <li>3. FOR USE WITH COPPER CONDUCTORS ONLY.</li> <li>4. LOW VOLTAGE CIRCUIT IS N.E.C. CLASS 2 WITH A CLASS 2 TRANSFORMER, 24V, 50/60 HZ SUPPLIED.</li> </ol>	VOLTAGES-HZ	TRANSFORMER	220-220 - 50 HZ	220 OR 240	220-220 - 60 HZ	220 OR 240	380V - 60 HZ	380	380V-415 - 60 HZ	380	460V - 60 HZ	460	575 - 60 HZ	575	<p><b>COMPONENT CODES</b></p> <table border="0"> <tr> <td>AUX</td> <td>AUXILIARY CONTACTOR</td> </tr> <tr> <td>CB</td> <td>CONTROL BOX</td> </tr> <tr> <td>CC</td> <td>COMPRESSOR CONTACTOR</td> </tr> <tr> <td>CCH</td> <td>CRANKCASE HEATER</td> </tr> <tr> <td>COMP</td> <td>COMPRESSOR</td> </tr> <tr> <td>CT</td> <td>CONTROL TRANSFORMER</td> </tr> <tr> <td>GND</td> <td>GROUND</td> </tr> <tr> <td>HPC</td> <td>HIGH PRESSURE CONTROL</td> </tr> <tr> <td>LPC</td> <td>LOW PRESSURE CONTROL</td> </tr> <tr> <td>OPM</td> <td>OUTDOOR FAN MOTOR</td> </tr> <tr> <td>RL</td> <td>RELAY</td> </tr> <tr> <td>TB</td> <td>TERMINAL BLOCK</td> </tr> <tr> <td>TDC</td> <td>TIME DELAY CONTROL</td> </tr> <tr> <td>WN</td> <td>WIRE NUT</td> </tr> </table>	AUX	AUXILIARY CONTACTOR	CB	CONTROL BOX	CC	COMPRESSOR CONTACTOR	CCH	CRANKCASE HEATER	COMP	COMPRESSOR	CT	CONTROL TRANSFORMER	GND	GROUND	HPC	HIGH PRESSURE CONTROL	LPC	LOW PRESSURE CONTROL	OPM	OUTDOOR FAN MOTOR	RL	RELAY	TB	TERMINAL BLOCK	TDC	TIME DELAY CONTROL	WN	WIRE NUT	<p><b>WIRE COLOR CODE</b></p> <table border="0"> <tr> <td>BK.....</td> <td>BLACK</td> <td>G.....</td> <td>GREEN</td> <td>PR.....</td> <td>PURPLE</td> </tr> <tr> <td>BR.....</td> <td>BROWN</td> <td>O.....</td> <td>ORANGE</td> <td>R.....</td> <td>RED</td> </tr> <tr> <td>BL.....</td> <td>BLUE</td> <td>PK.....</td> <td>PINK</td> <td>Y.....</td> <td>YELLOW</td> </tr> </table> <p><b>ELECTRICAL WIRING DIAGRAM</b></p> <p>CONDENSING UNIT          12.5, 15, AND 20 TON          208-230, 380, 460 3PH 60Hz &amp;          200-220, 380-415 3PH 50Hz &amp;          575 3PH 60Hz</p>	BK.....	BLACK	G.....	GREEN	PR.....	PURPLE	BR.....	BROWN	O.....	ORANGE	R.....	RED	BL.....	BLUE	PK.....	PINK	Y.....	YELLOW
VOLTAGES-HZ	TRANSFORMER																																																														
220-220 - 50 HZ	220 OR 240																																																														
220-220 - 60 HZ	220 OR 240																																																														
380V - 60 HZ	380																																																														
380V-415 - 60 HZ	380																																																														
460V - 60 HZ	460																																																														
575 - 60 HZ	575																																																														
AUX	AUXILIARY CONTACTOR																																																														
CB	CONTROL BOX																																																														
CC	COMPRESSOR CONTACTOR																																																														
CCH	CRANKCASE HEATER																																																														
COMP	COMPRESSOR																																																														
CT	CONTROL TRANSFORMER																																																														
GND	GROUND																																																														
HPC	HIGH PRESSURE CONTROL																																																														
LPC	LOW PRESSURE CONTROL																																																														
OPM	OUTDOOR FAN MOTOR																																																														
RL	RELAY																																																														
TB	TERMINAL BLOCK																																																														
TDC	TIME DELAY CONTROL																																																														
WN	WIRE NUT																																																														
BK.....	BLACK	G.....	GREEN	PR.....	PURPLE																																																										
BR.....	BROWN	O.....	ORANGE	R.....	RED																																																										
BL.....	BLUE	PK.....	PINK	Y.....	YELLOW																																																										
<p>APPROVED: _____</p>	<p>CHECKED: _____</p>	<p>ORIGINAL RELEASE NO. _____</p>	<p>REV: 02</p>																																																												
<p>MOELED BY: _____</p>	<p>VYM DATE: 11-19-19</p>	<p>Y-0699S169</p>	<p>PART NO.: 90-108041-01</p>																																																												

# 11.0 WIRING DIAGRAMS

## 11.3 (-)ACL2150, (-)ACL2180, (-)ACL2240 WIRING SCHEMATIC (12.5, 15 & 20 TON)

