



Versus™ Line iC Air Conditioners



WSA14AZ

Cooling Efficiencies up to: 15.2 SEER2/12 EER2

Nominal Sizes: 1½ to 2.5 Ton [5.28 to 8.79 kW]

Cooling Capacities: 17.1 to 27.5 kBTU [5.0 to 8.1 kW]



† A.F.U.E. (Annual Fuel Utilization Efficiency) calculated in accordance with Department of Energy test procedures.

****Proper sizing and installation of equipment is critical to achieve optimal performance. Split system air conditioners and heat pumps must be matched with appropriate coil components to meet Energy Star. Ask your Contractor for details or visit www.energystar.gov.***

Table of Contents

Features & Benefits	3
Model Number Identification	4
General Data/Electrical Data	5
Accessories	6
Weighted Sound Power	6
Unit Dimensions	7
Clearances	8
Control Wiring	9
Application Guidelines.....	9
Refrigerant Line Size Information	10-13
Performance Data	14
Limited Warranty	16

Features and Benefits

- **Fully Louvered Steel Cabinet:** Features durable construction to add protection from yard hazards, weather corrosion
- **Optimized 7 mm Coil Design:** Allows for improved airflow, heat transfer and energy consumption
- **Easily Accessible Control Box:** Ease of installation and serviceability

Air Conditioners

<u>W</u>	<u>SA</u>	<u>14</u>	<u>A</u>	<u>Z</u>	<u>18</u>	<u>A</u>	<u>J</u>	<u>1</u>	<u>N</u>	<u>A</u>
Brand	Product Category	SEER2	Region	Refrigerant	Capacity	Major Series	Voltage	Type	Controls	Minor Series
W - WeatherKing	SA - Legacy AC	14 - 14.3 SEER2	A - All Regions	Z - R-410A	18 - 1.5T 24 - 2.0T 30 - 2.5T	A - 1st Design	J - 208/230/1/60	1 - 1-Stage	N - Non-Communicating	A - 1st Design

[] Designates Metric Conversions

AVAILABLE MODELS
WSA14AZ18AJ1NA
WSA14AZ24AJ1NA
WSA14AZ30AJ1NA

STANDARD EQUIPMENT
R410-A Refrigerant
Scroll Compressor
Field Installed Filter Drier
Front Seating Service Valves
Internal Pressure Relief Valve
Internal Thermal Overload
Long Line Capability
Low Ambient Capability with Kit
Optimized Venturi Airflow
Rust Resistant Screws
QR Code
External Gauge Ports

General Data			
MODEL NO.	WSA14AZ18A	WSA14AZ24A	WSA14AZ30A
Nominal Tonnage	1.5	2.0	2.5
Valve Connections			
Liquid Line O.D. – in.	3/8	3/8	3/8
Suction Line O.D. – in.	3/4	3/4	3/4
Refrigerant (R410A) furnished oz.¹	118	123	146
Compressor Type	Scroll		
Outdoor Coil			
Net face area – Outer Coil	14.5	14.5	18.1
Net face area – Inner Coil	13.9	13.9	17.5
Tube diameter – in.	0.276	0.276	0.276
Number of rows	2	2	2
Fins per inch	22	22	22
Outdoor Fan			
Diameter – in.	18	18	22
Number of blades	3	3	2
Motor hp	1/7	1/7	1/6
CFM	2036	2036	2546
RPM	1075	1075	825
watts	154	154	165
Shipping weight – lbs.	151	151	170
Operating weight – lbs.	159	159	177
Electrical Data			
Line Voltage Data (Volts-Phase-Hz)	208/230-1-60	208/230-1-60	208/230-1-60
Maximum overcurrent protection (amps)²	20	25	25
Minimum circuit ampacity³	13	16	17
Compressor			
Rated load amps	9	12	13
Locked rotor amps	43	60	65
Condenser Fan Motor			
Full load amps	0.8	0.8	0.8
Locked rotor amps	1.7	1.7	1.7

¹Refrigerant charge sufficient for 15 ft. length of refrigerant lines. For longer line set requirements see the installation instructions for information about set length and additional refrigerant charge required.

²HACR type circuit breaker or fuse.

³Refer to National Electrical Code manual to determine wire, fuse and disconnect size requirements.

Accessories

MODEL NO.		WSA14AZ18A	WSA14AZ24A	WSA14AZ30A
Compressor crankcase heater*		44-17402-44	44-17402-44	44-17402-44
Low ambient control		RXAD-A08	RXAD-A08	RXAD-A08
Compressor sound cover		68-23427-26	68-23427-26	68-23427-26
Compressor hard start kit		SK-A1	SK-A1	SK-A1
Compressor time delay		RXMD-B01	RXMD-B01	RXMD-B01
Low pressure control		RXAC-A07	RXAC-A07	RXAC-A07
High pressure control		RXAB-A07	RXAB-A07	RXAB-A07
Liquid Line Solenoid (24 VAC, 50/60 Hz)	Solenoid Valve	200RD2T3TVLC	200RD2T3TVLC	200RD2T3TVLC
	Solenoid Coil	61-AMG24V	61-AMG24V	61-AMG24V
Liquid Line Solenoid (120/240 VAC, 50/60 Hz)	Solenoid Valve	200RD2T3TVLC	200RD2T3TVLC	200RD2T3TVLC
	Solenoid Coil	61-AMG120/240V	61-AMG120/240V	61-AMG120/240V

*Crankcase Heater recommended with Low Ambient Kit.

Weighted Sound Power Level (dBA)

UNIT SIZE - VOLTAGE, SERIES	STANDARD RATING (DBA)	TYPICAL OCTAVE BAND SPECTRUM (DBA WITHOUT TONE ADJUSTMENT)						
		125	250	500	1000	2000	4000	8000
WSA14AZ18A	76.0	56.7	59.5	62.1	66.1	64.7	62.5	62.6
WSA14AZ24A	76.0	56.6	57.9	62.6	67.2	65.5	61.1	58.0
WSA14AZ30A	74.0	46.7	55.2	62.8	66.1	60.4	57.3	51.2

NOTE: Tested in accordance with AHRI Standard 270-08 (not listed in AHRI)

Unit Dimensions

MODEL NO.	OPERATING						SHIPPING					
	H (Height)		L (Length)		W (Width)		H (Height)		L (Length)		W (Width)	
	INCHES	mm	INCHES	mm	INCHES	mm	INCHES	mm	INCHES	mm	INCHES	mm
WSA14AZ18A	32.25	819	23.63	600	23.63	600	32.50	826	24.75	629	24.75	629
WSA14AZ24A	32.25	819	23.63	600	23.63	600	32.50	826	24.75	629	24.75	629
WSA14AZ30A	32.25	819	27.63	702	27.63	702	32.50	826	28.75	730	28.75	730

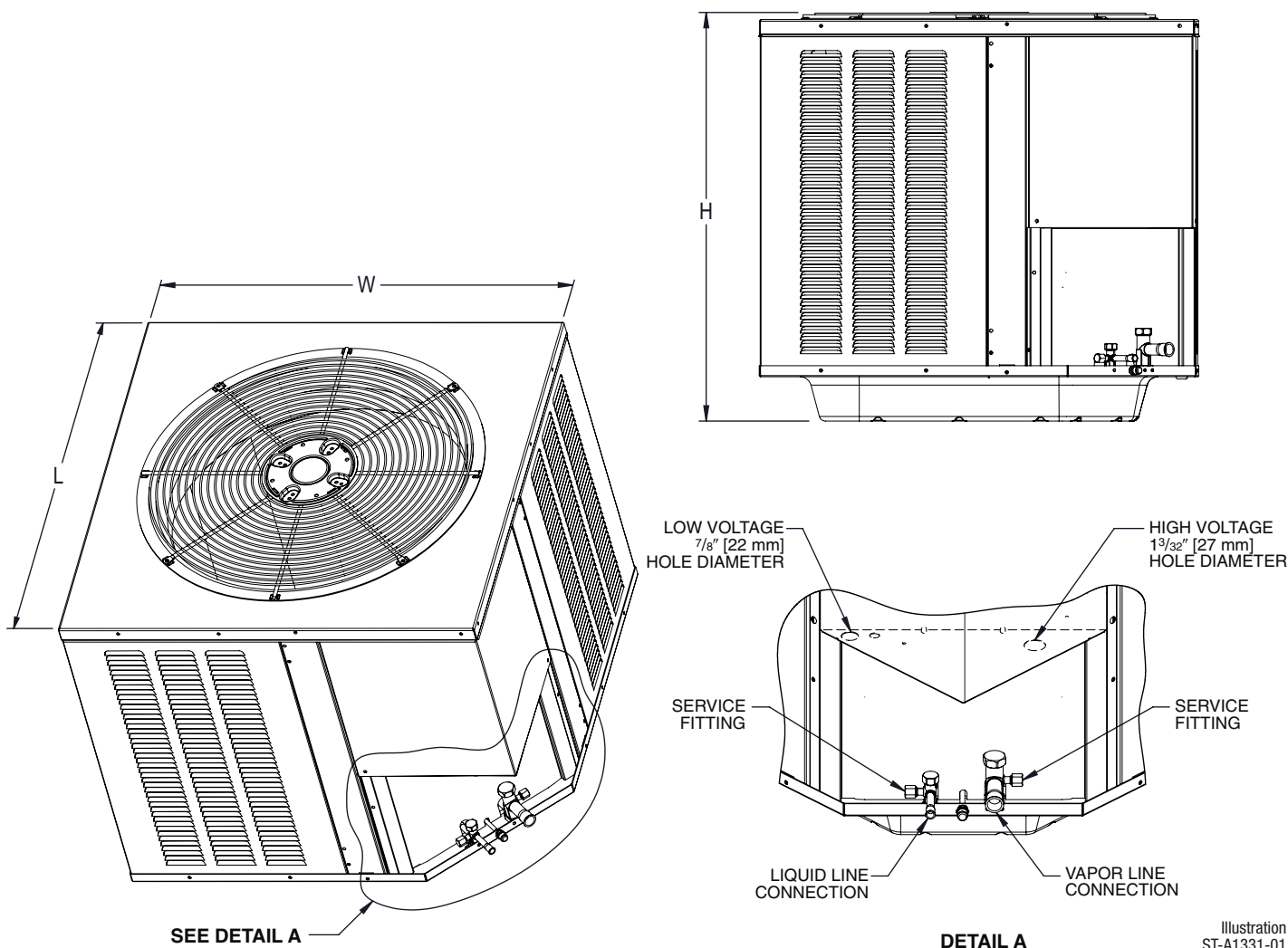

NOTE: Illustrations show the deep drawn basepan.

[] Designates Metric Conversions

Illustration
ST-A1331-01
Rev. 10-20-2022

CLEARANCES

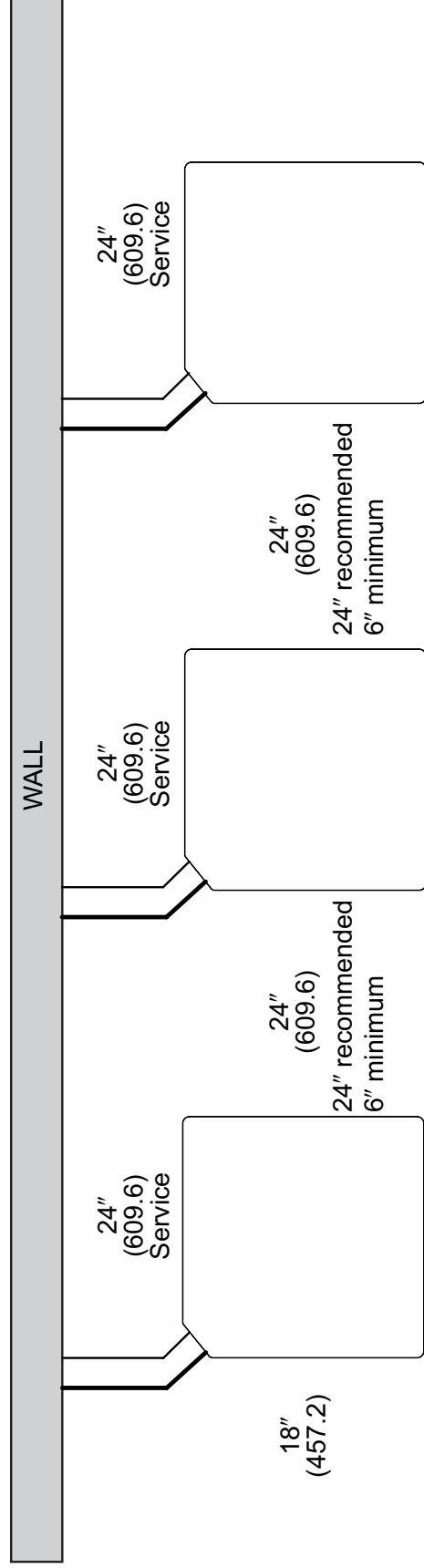
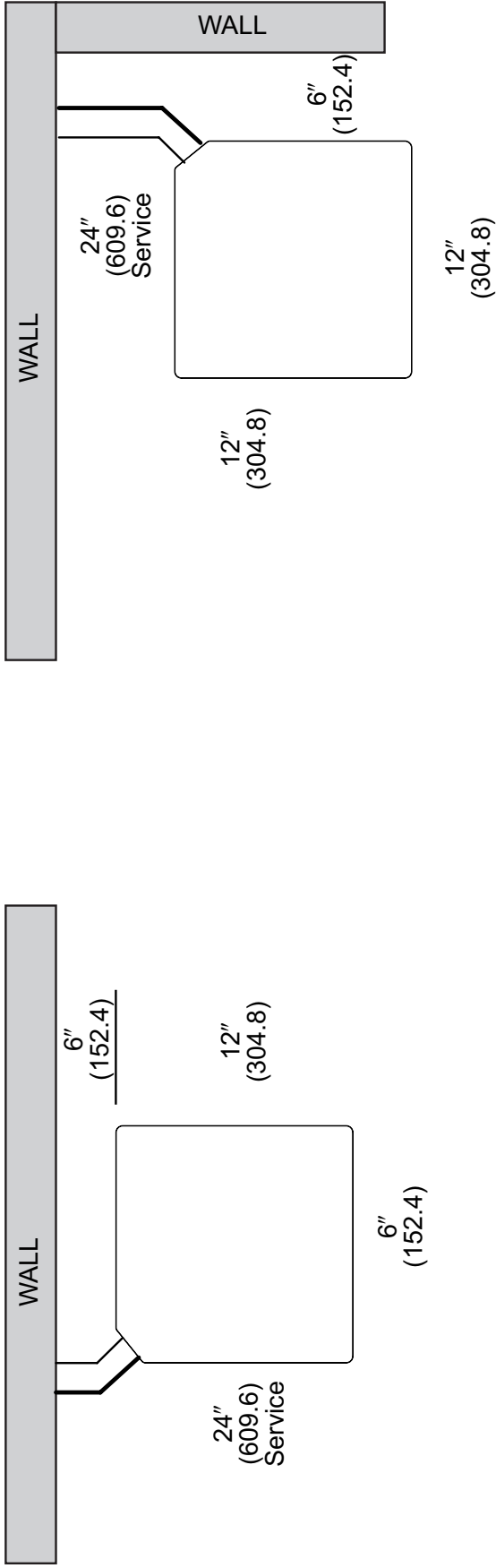

NOTE: NUMBERS IN () = mm

IMPORTANT: When installing multiple units in an alcove, roof well or partially enclosed area, ensure there is adequate ventilation to prevent re-circulation of discharge air.

Control Wiring

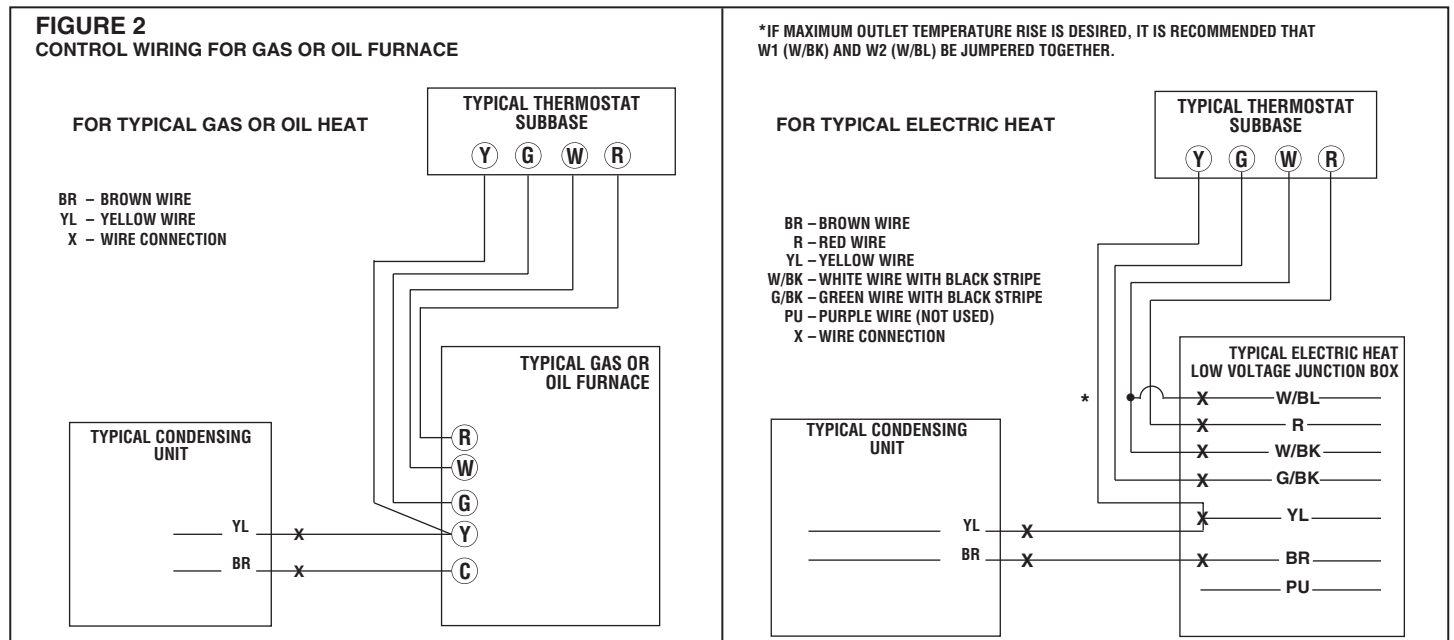

Application Guidelines

1. Intended for outdoor installation with free air inlet and outlet. Outdoor fan external static pressure available is less than 0.01 -in. wc.
2. Minimum outdoor operation air temperature for cooling mode without low-ambient operation accessory is 55°F (12.8°C).
3. Maximum outdoor operating air temperature is 125°F (51.7°C).
4. For reliable operation, unit should be level in all horizontal planes.
5. Use only copper wire for electric connections at unit. Aluminum and clad aluminum are not acceptable for the type of connector provided.
6. Do not apply capillary tube indoor coils to these units.
7. Factory-supplied filter drier must be installed.

Refrigerant Line Size Information

14.3 SEER2 SINGLE-STAGE AIR CONDITIONERS															
UNIT SIZE	ALLOWABLE LIQUID LINE SIZE	ALLOWABLE SUCTION LINE SIZE	APPLY LONG LINE GUIDELINES IF LINEAR LINE LENGTH EXCEEDS THOSE SHOWN BELOW (FEET)	EQUIVALENT LENGTH (FEET)											
				< 25	26-50	51-75	76-100	101-125	126-150	151-175	176-200	201-225	226-250		
				MAXIMUM VERTICAL RISE (OUTDOOR UNIT BELOW INDOOR UNIT) * / CAPACITY MULTIPLIER											
1.5 Ton **SEE NOTE 3	1/4"	5/8"	/	25/1.00	50/0.99	62/0.98	43/0.98	24/0.97	5/0.97	NR	NR	NR	NR	NR	NR
	5/16"	5/8"	188	25/1.00	50/0.99	75/0.98	98/0.98	93/0.97	88/0.97	83/0.96	78/0.96	73/0.95	68/0.94	100/0.94	100/0.94
	3/8"	5/8"	125	25/1.00	50/0.99	75/0.98	100/0.98	100/0.97	100/0.97	100/0.96	100/0.96	100/0.95	100/0.94	100/0.94	100/0.94
	1/4"	3/4"***	/	25/1.00	50/1.00	62/0.99	43/0.99	24/0.99	5/0.99	NR	NR	NR	NR	NR	NR
	5/16"	3/4"***	188	25/1.00	50/1.00	75/0.99	98/0.99	93/0.99	88/0.99	83/0.99	78/0.98	73/0.98	68/0.98	100/0.98	100/0.98
	3/8"	3/4"***	125	25/1.00	50/1.00	75/1.00	100/0.99	100/0.99	100/0.99	100/0.99	100/0.99	100/0.98	100/0.98	100/0.98	100/0.98
2 Ton	1/4"	5/8"	/	25/0.99	50/0.98	21/0.97	NR	NR	NR	NR	NR	NR	NR	NR	NR
	5/16"	5/8"	180	25/0.99	50/0.98	75/0.97	87/0.96	77/0.95	69/0.94	61/0.93	53/0.92	45/0.91	37/0.90	89/0.90	89/0.90
	3/8"	5/8"	120	25/0.99	50/0.98	75/0.97	100/0.96	100/0.95	100/0.94	98/0.93	95/0.92	92/0.91	89/0.90	89/0.90	89/0.90
	1/4"	3/4"	/	25/1.00	50/1.00	21/0.99	NR	NR	NR	NR	NR	NR	NR	NR	NR
	5/16"	3/4"	180	25/1.00	50/1.00	75/0.99	87/0.99	77/0.98	69/0.98	61/0.98	53/0.97	45/0.97	37/0.96	89/0.96	89/0.96
	3/8"	3/4"	120	25/1.00	50/1.00	75/0.99	100/0.99	100/0.98	100/0.98	100/0.98	98/0.98	95/0.97	93/0.97	90/0.96	90/0.96
2.5 Ton	5/16"	5/8"	148	25/0.99	50/0.98	75/0.96	70/0.94	59/0.93	48/0.91	36/0.90	NR	NR	NR	NR	NR
	3/8"	5/8"	98	25/0.99	50/0.98	75/0.96	100/0.94	98/0.93	94/0.91	90/0.90	NR	NR	NR	NR	NR
	5/16"	3/4"	148	25/1.00	50/0.99	75/0.99	70/0.98	59/0.98	48/0.97	36/0.96	25/0.96	13/0.95	NR	NR	NR
	3/8"	3/4"	98	25/1.00	50/0.99	75/0.99	100/0.98	98/0.98	94/0.97	90/0.96	86/0.96	82/0.95	78/0.95	78/0.95	78/0.95

NOTES:

- 1) Do not exceed 200 ft linear line length.
- 2) *Do not exceed 100 ft vertical separation if outdoor unit is above indoor unit.
- 3) **3/4" suction line should only be used for 1.5 ton systems if outdoor unit is below or at same level as indoor to assure proper oil return.
- 4) Always use the smallest liquid line allowable to minimize refrigerant charge.
- 5) Applications shaded in light gray indicate capacity multipliers between 0.90 and 0.96 which are not recommended, but are allowed.
- 6) Applications shaded in dark gray are not recommended due to excessive liquid or suction pressure drop.

Refrigerant Line Size Information (Con't.)

14.3 SEER2 SINGLE-STAGE AIR CONDITIONERS													
UNIT SIZE	ALLOWABLE LIQUID LINE SIZE MM [IN.]	ALLOWABLE SUCTION LINE SIZE MM [IN.]	APPLY LONG LINE GUIDELINES IF LINEAR LINE LENGTH EXCEEDS THOSE SHOWN BELOW (METERS) (-)JA14A	EQUIVALENT LENGTH (METERS)									
				< 8	8-15	16-23	24-30	31-38	39-46	47-53	54-61	62-69	70-76
				MAXIMUM VERTICAL RISE (OUTDOOR UNIT BELOW INDOOR UNIT) * / CAPACITY MULTIPLIER									
5.3 KW [1.5 Ton] **SEE NOTE 3	6.35 [1/4]	15.88 [5/8]	/	8 / 1.00	15 / 0.99	19 / 0.98	13 / 0.98	7 / 0.97	2 / 0.97	NR	NR	NR	NR
	7.94 [5/16]	15.88 [5/8]	57	8 / 1.00	15 / 0.99	23 / 0.98	30 / 0.98	28 / 0.97	27 / 0.97	25 / 0.96	24 / 0.96	22 / 0.95	21 / 0.94
	9.53 [3/8]	15.88 [5/8]	38	8 / 1.00	15 / 0.99	23 / 0.98	30 / 0.98	30 / 0.97	30 / 0.97	30 / 0.96	30 / 0.96	30 / 0.95	30 / 0.94
	6.35 [1/4]	19.05 [3/4]**	/	8 / 1.00	15 / 1.00	19 / 0.99	13 / 0.99	7 / 0.99	2 / 0.99	NR	NR	NR	NR
	7.94 [5/16]	19.05 [3/4]**	57	8 / 1.00	15 / 1.00	23 / 0.99	30 / 0.99	28 / 0.99	27 / 0.99	25 / 0.99	24 / 0.98	22 / 0.98	21 / 0.98
	9.53 [3/8]	19.05 [3/4]**	38	8 / 1.00	15 / 1.00	23 / 0.99	30 / 0.99	30 / 0.99	30 / 0.99	30 / 0.99	30 / 0.99	30 / 0.98	30 / 0.98
7.0 KW [2 Ton]	6.35 [1/4]	15.88 [5/8]	/	8 / 0.99	15 / 0.98	6 / 0.97	NR	NR	NR	NR	NR	NR	NR
	7.94 [5/16]	15.88 [5/8]	55	8 / 0.99	15 / 0.98	23 / 0.97	27 / 0.96	23 / 0.95	21 / 0.94	19 / 0.93	16 / 0.92	14 / 0.91	11 / 0.90
	9.53 [3/8]	15.88 [5/8]	37	8 / 0.99	15 / 0.98	23 / 0.97	30 / 0.96	30 / 0.95	30 / 0.94	30 / 0.93	29 / 0.92	28 / 0.91	27 / 0.90
	6.35 [1/4]	19.05 [3/4]	/	8 / 1.00	15 / 1.00	6 / 0.99	NR	NR	NR	NR	NR	NR	NR
	7.94 [5/16]	19.05 [3/4]	55	8 / 1.00	15 / 1.00	23 / 0.99	27 / 0.99	23 / 0.98	21 / 0.98	19 / 0.98	16 / 0.97	14 / 0.97	11 / 0.96
	9.53 [3/8]	19.05 [3/4]	37	8 / 1.00	15 / 1.00	23 / 0.99	30 / 0.99	30 / 0.98	30 / 0.98	30 / 0.98	29 / 0.97	28 / 0.97	27 / 0.96
8.8 KW [2.5 Ton]	7.94 [5/16]	15.88 [5/8]	45	8 / 0.99	15 / 0.98	23 / 0.96	21 / 0.94	18 / 0.93	15 / 0.91	11 / 0.90	NR	NR	NR
	9.53 [3/8]	15.88 [5/8]	30	8 / 0.99	15 / 0.98	23 / 0.96	30 / 0.94	30 / 0.93	29 / 0.91	27 / 0.90	NR	NR	NR
	7.94 [5/16]	19.05 [3/4]	45	8 / 1.00	15 / 0.99	23 / 0.99	21 / 0.98	18 / 0.98	15 / 0.97	11 / 0.96	8 / 0.96	4 / 0.95	NR
	9.53 [3/8]	19.05 [3/4]	30	8 / 1.00	15 / 0.99	23 / 0.99	30 / 0.98	30 / 0.98	29 / 0.97	27 / 0.96	26 / 0.96	25 / 0.95	24 / 0.95

NOTES:

- 1) Do not exceed 61m linear line length.
- 2) *Do not exceed 30m vertical separation if outdoor unit is above indoor unit.
- 3) **19.05mm suction line should only be used for 1.5 ton systems if outdoor unit is below or at same level as indoor to assure proper oil return.
- 4) Always use the smallest liquid line allowable to minimize refrigerant charge.
- 5) Applications shaded in light gray indicate capacity multipliers between 0.90 and 0.96 which are not recommended, but are allowed.
- 6) Applications shaded in dark gray are not recommended due to excessive liquid or suction pressure drop.

Performance Data @ AHRI Standard Conditions – Cooling

DESIGNATED TESTED COMBINATION (DTC)							
OUTDOOR UNIT	INDOOR COIL	TOTAL CAPACITY BTU/H [KW]	NET SENSIBLE BTU/H [KW]	NET LATENT BTU/H [KW]	SEER2	EER2	INDOOR CFM [L/S]
WSA14AZ18AJ1	TCFZ2417STAN	17,100 [5.0]	13,100 [3.8]	4,000 [1.2]	14.3	11.7	600 [283.2]
WSA14AZ24AJ1	TCFZ3617STAN	22,800 [6.7]	17,000 [5.0]	5,800 [1.7]	14.3	11.7	735 [346.9]
WSA14AZ30AJ1	TCFZ3617STAN	27,500 [8.1]	19,900 [5.8]	7,600 [2.2]	14.3	11.7	910 [429.5]

NOTE: This data includes DTC (Designated Test Combination) ratings and is for reference purposes only. A full listing of official ratings and system match-ups, along with downloadable certificates, can be accessed from the AHRI website: www.ahridirectory.org.

[] Designates Metric Conversions



GENERAL TERMS OF LIMITED WARRANTY*

WeatherKing will furnish a replacement for any part of this product which fails in normal use and service within the applicable period stated, in accordance with the terms of the limited warranty.

PartsFive (5) Years

***For complete details of the Limited and Conditional Warranties, including applicable terms and conditions, contact your local contractor or the Manufacturer for a copy of the product warranty certificate.**

Before proceeding with installation, refer to installation instructions packaged with each model, as well as complying with all Federal, State, Provincial, and Local codes, regulations, and practices.

© 2023 Rheem Manufacturing Company. WeatherKing trademarks owned by Rheem Manufacturing Company.

"In keeping with its policy of continuous progress and product improvement, WeatherKing reserves the right to make changes without notice."

WeatherKing • 5600 Old Greenwood Road
Fort Smith, Arkansas 72908 • www.weatherking.com

Rheem Canada Ltd./Ltée • 125 Edgeware Road, Unit 1
Brampton, Ontario • L6Y 0P5 • weatherking.ca